

Sidokanalfläktar



Beskrivning

Direkt drivna sidokanalfläktar för oljefri och pulsationsfri transport av luft och icke-aggressiva & icke-explosiva gaser, eller för alstring av över- eller undertryck. 2-poliga TEFC asynkronmotorer i skyddsklass IP-55, isolationsklass F för motorer under 1,5kW och isolationsklass H fr.o.m. 2,2kW och över. Samtliga motorer är i standardutförande försedda med Klixon termokontakter. Sug- och trycksida är försedda med ljuddämpare samt invändigt gängade röranslutningar fr.o.m storlek 2210. Underhållsfri axelgenomföring med tätning som separerar motorn från fläkthuset. Fläkthus, fläkthjul samt motorhölje är tillverkat i pressgjuten aluminium. Remdrivna fläktar och fläktar med kundanpassad kapacitet kan levereras på begäran/förfrågan. Andra spänningar, isolationsklass etc. på begäran.

Driftsäkerhet

Effektbehovet (Ampere) ökar ju högre vakuüm eller tryck som fläkten alstrar. Därför skall skyddsbrytare alltid installeras för att inte motorn skall kunna överbelastas. Fläkten är med sin utvecklade design och konstruktion, mycket driftsäker och helt underhållsfri. EKB sidokanalfläktar har också kullager med lång livslängd på varje ända av motoraxeln, utanför själva fläkthuset. Fördelarna med detta är bl.a. lägre temperatur på lager, längre livslängd på lagerfett samt enkel åtkomlighet vid ev. lagerbyte.

Enkel Installation

EKB sidokanalfläkt är en komplett enhet klar att installera, som vakuumpump eller tryckande fläkt.

Användningsområden

Pneumatiska transportsystem och vakuümsystem, industridammsugare och stoftsugsystem, tryckmaskiner, dentalutsug, syresättning i dammar och reningsverk, buteljeringsanläggning.

Benämningsskod

HB	2	7	1	3	-	300	T
Fläkttyp	Serie	Storlek	Fläkthus typ	0-standard 3-förhöjt flöde		Effektfaktor 3kwx100=300	T- trefas S- enfas
			1-enkelt 2-dubbelt serie 3-trippelt 4-Dubbelt paral.				

Enkelsteg HB 2.1.

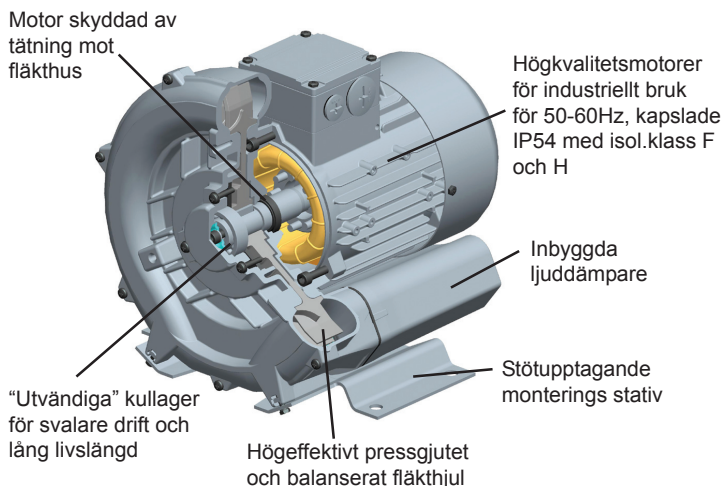

Dubbeltsteg HB 2.2. & HB 2.4.

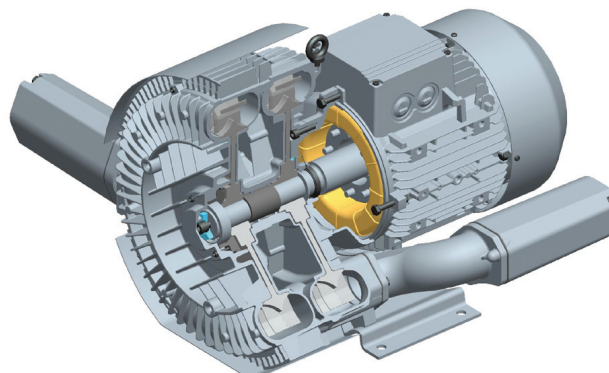

HB 2210/2213



HB 2510/2513



HB 2710/2713

HB 2810/2813



HB 2220/2320



HB 2420/2520

Exempel på Special-/kund-specifika utföranden



Monterad på stativ



Monterad i rostfri box med styrning

TYP	Frekvens Hz	Motoreffekt kW	Spänning V	Märkström A	Flöde max m3/h	Max vakuüm mbar	Max tryck mbar	Ljud dB	Vikt KG
HB 2010-020S	50	0,2	230	1,43	40	-60	70	50	6
	60	0,23	230	1,3	55	-60	70	51	
HB 2110-025S	50	0,25	230	1,7	55	-80	80	51	7
	60	0,28	230	1,9	60	-80	80	52	
HB 2210-037S	50	0,37	230	2,7	80	-110	110	53	11
	60	0,45	230	3	96	-130	140	56	
HB 2213-037S	50	0,37	230	2,7	100	-110	110	54	11
	60	0,45	230	3	120	-130	140	57	
HB 2220-070S	50	0,7	230	4,5	88	-210	240	55	15
	60	0,83	230	5,6	103	-250	250	61	
HB 2310-055S	50	0,55	230	3,7	100	-120	120	55	13
	60	0,62	230	4,5	120	-130	150	57	
HB 2310-070S	50	0,7	230	4,8	100	-150	150	55	14
	60	0,8	230	4,1	120	-150	160	57	
HB 2320-110S	50	1,1	230	7,3	120	-240	280	58	17
	60	1,3	230	8,3	145	-230	260	60	
HB 2313-070S	50	0,7	230	4,8	145	-100	100	56	14
	60	0,8	230	4,1	165	-110	100	58	
HB 2410-080S	50	0,8	230	5,2	145	-150	160	63	15
	60	0,9	230	5,8	175	-160	140	64	
HB 2410-110S	50	1,1	230	7,3	145	-150	190	63	16
	60	1,3	230	8,3	175	-180	190	64	
HB 2413-080S	50	0,8	230	5,2	180	-100	110	64	16
	60	0,9	230	5,8	210	-100	110	66	
HB 2413-110S	50	1,1	230	7,3	180	-170	210	64	17
	60	1,3	230	8,3	210	-145	145	66	
HB 2420-150S	50	1,5	230	9	150	-280	290	66	26
	60	1,75	230	10	180	-250	280	69	
HB 2510-110S	50	1,1	230	7,3	210	-160	160	64	21
	60	1,3	230	8,3	255	-150	160	70	
HB 2510-150S	50	1,5	230	9	210	-190	200	64	24
	60	1,75	230	10	255	-180	180	70	
HB 2513-150S	50	1,5	230	9	270	-140	120	65	26
	60	1,75	230	10	330	-110	100	71	
HB 2710-220S	50	2,2	230	12,8	318	-190	190	72	30
	60	2,55	230	12,8	376	-190	200	74	

Mått

Typ	A	B	C	D	E	F	G	H	J	K	L	M	N	O	ØP	Q	ØR	S	U	V	V'	ØX	YxZ
HB 2010-020S	198	212	85	179	196	220	108	115	100	65	90	40	45	34	1"	60	8,5	2	M6x17	-	-	119	M6x15
HB 2110-025S	221	235	94	190	207	225	118	118	100	77	100	33	53	38	1"	64	8,5	2	M6x17	-	-	132	M6x15
HB 2210-037S	246	247	90	205	230	256	135	128	111	83	108	75	71	39	1 1/4"	64	10	2,5	M6x17	M16x1,5	M25x1,5	140	M6x15
HB 2213-037S	246	247	90	205	230	267	135	128	111	83	108	75	82	39	1 1/4"	64	10	2,5	M6x17	M16x1,5	M25x1,5	140	M6x15
HB 2310-055S	268	272	93	205	230	260	135	141	111	83	108	82	69	41	1 1/4"	64	10	2,5	M6x17	M25x1,5	M16x1,5	160	M6x15
HB 2310-070S	268	272	93	205	230	260	135	141	111	83	108	82	69	41	1 1/4"	64	10	2,5	M6x17	M25x1,5	M16x1,5	160	M6x15
HB 2320-110S	293	286	47	205	230	354	160	141	120	83	108	82	138	41	1 1/4"	64	12	3	M6x17	M25x1,5	M16x1,5	160	M6x15
HB 2313-070S	268	272	93	205	230	276	135	141	111	83	108	82	85	41	1 1/4"	64	10	2,5	M6x17	M25x1,5	M16x1,5	160	M6x15
HB 2410-080S	286	302	115	225	255	294	160	154	120	95	130	70	75	46	1 1/2"	72	12	3	M6x19	M16x1,5	M25x1,5	174	-
HB 2410-110S	286	302	115	225	255	294	160	154	120	95	130	70	75	46	1 1/2"	72	12	3	M6x19	M16x1,5	M25x1,5	174	-
HB 2413-080S	286	302	115	225	255	311	160	154	120	95	130	70	75	46	1 1/2"	72	12	3	M6x19	M16x1,5	M25x1,5	174	-
HB 2413-110S	286	302	115	225	255	311	160	154	120	95	130	70	75	46	1 1/2"	72	12	3	M6x19	M16x1,5	M25x1,5	174	-
HB 2420-150S	322	315	58	225	255	401	191	154	128	95	130	73	151	45	1 1/2"	72	12	3	M6x19	M25x1,5	M16x1,5	174	M6x15
HB 2510-110S	334	337	120	260	295	314	160	175	120	115	155	96	87	48	55	83	14	4	M8x17	M16x1,5	M25x1,5	200	M8x20
HB 2510-150S	334	337	120	260	295	345	191	175	128	115	155	96	87	48	55	83	14	4	M8x17	M16x1,5	M25x1,5	200	M8x20
HB 2513-150S	334	337	120	260	295	365	191	175	128	115	155	96	87	48	55	83	14	4	M8x17	M16x1,5	M25x1,5	200	M8x20
HB 2710-220S	382	384	125	290	325	377	191	197	128	140	180	84	109	54	55	83	15	4,5	M8x17	M25x1,5	M16x1,5	240	M10x20

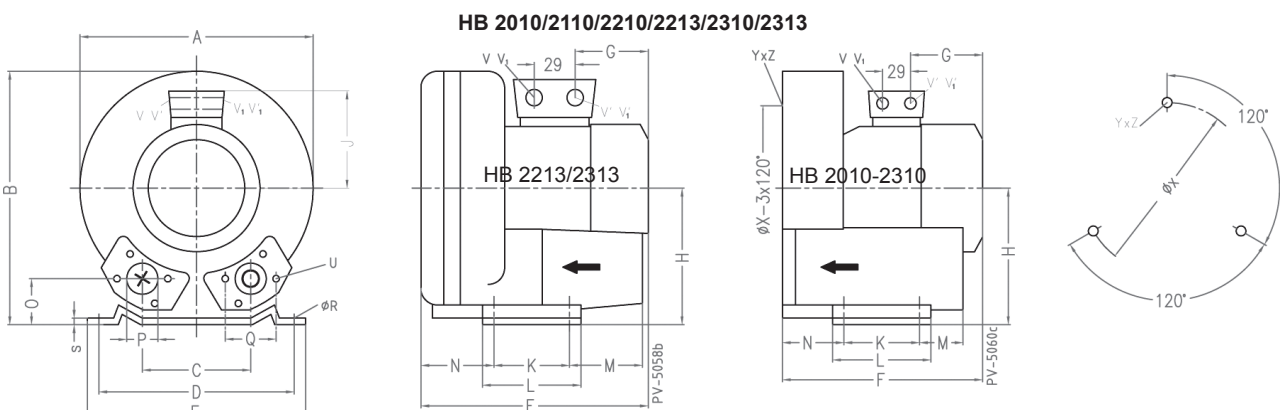

Mått

HB 2220/2320/2420

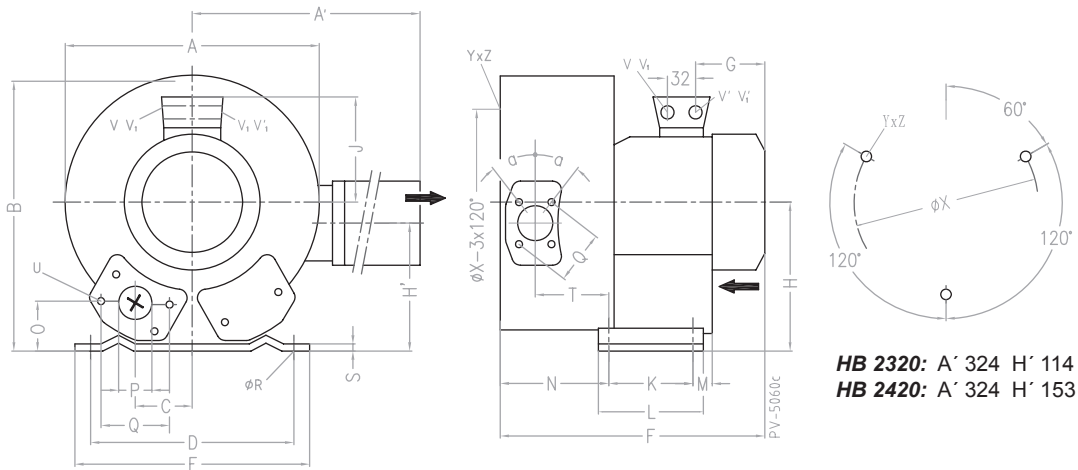

HB 2320: A' 324 H' 114
HB 2420: A' 324 H' 153

HB 2410/2413/2419

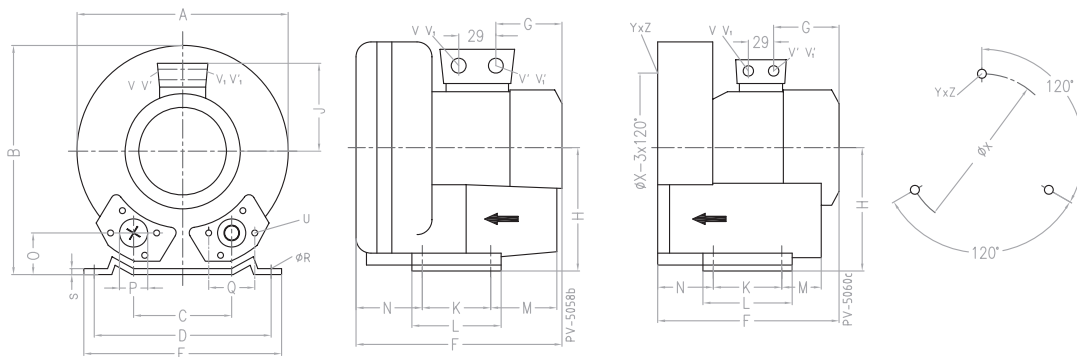

HB 2510/2513/2519

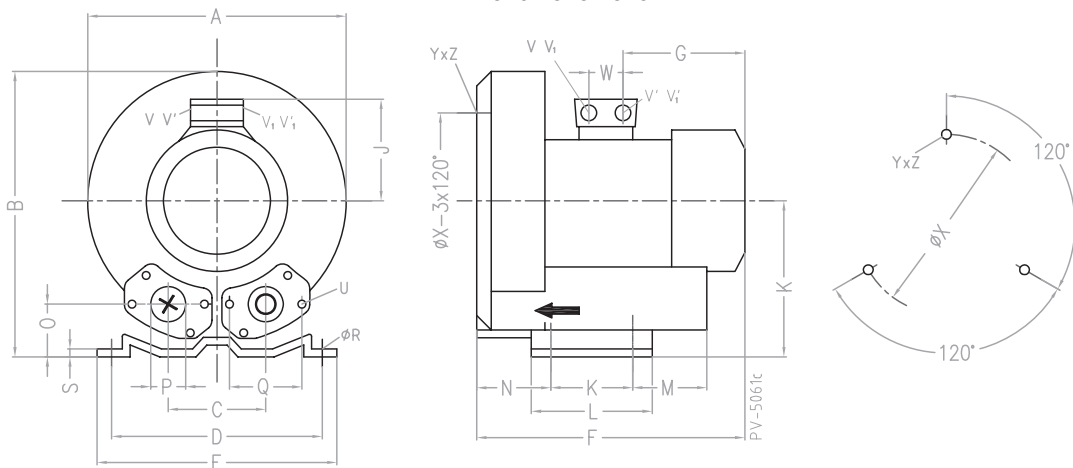

HB 2510/2513/2519

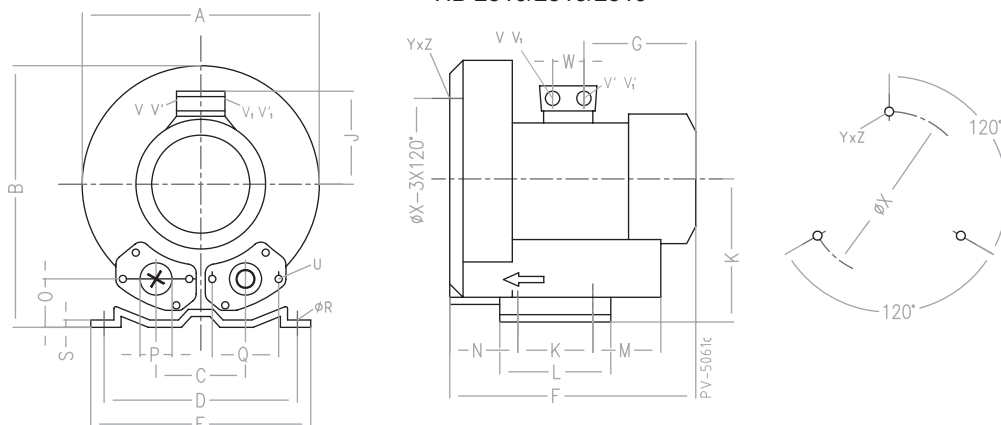

Flödesdiagram 50Hz

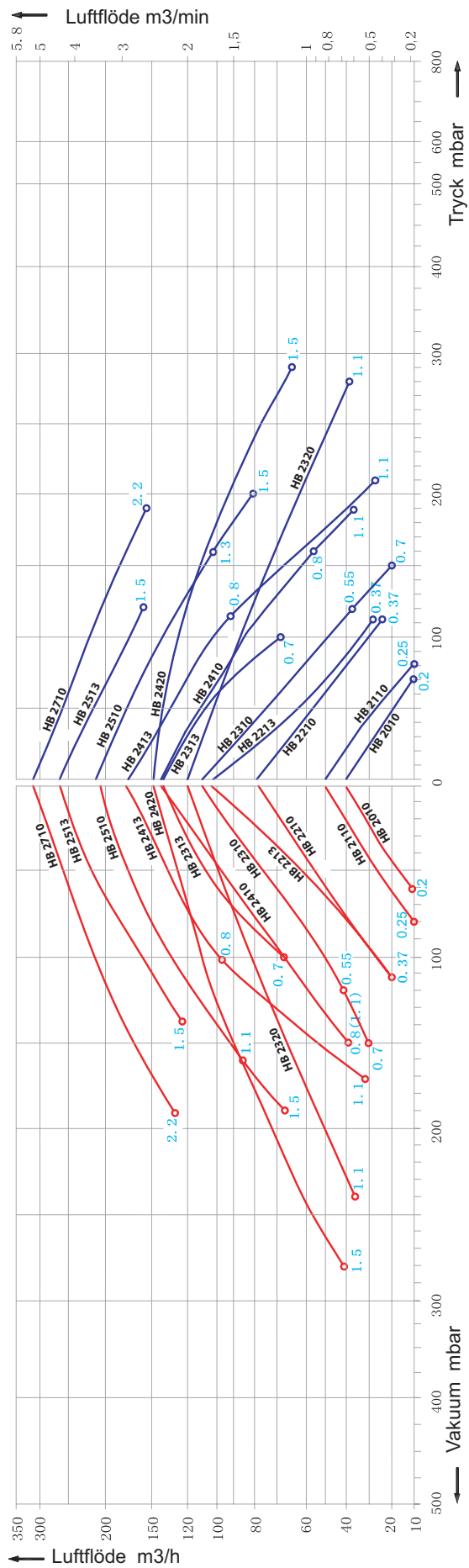

Flödesdiagram 60Hz

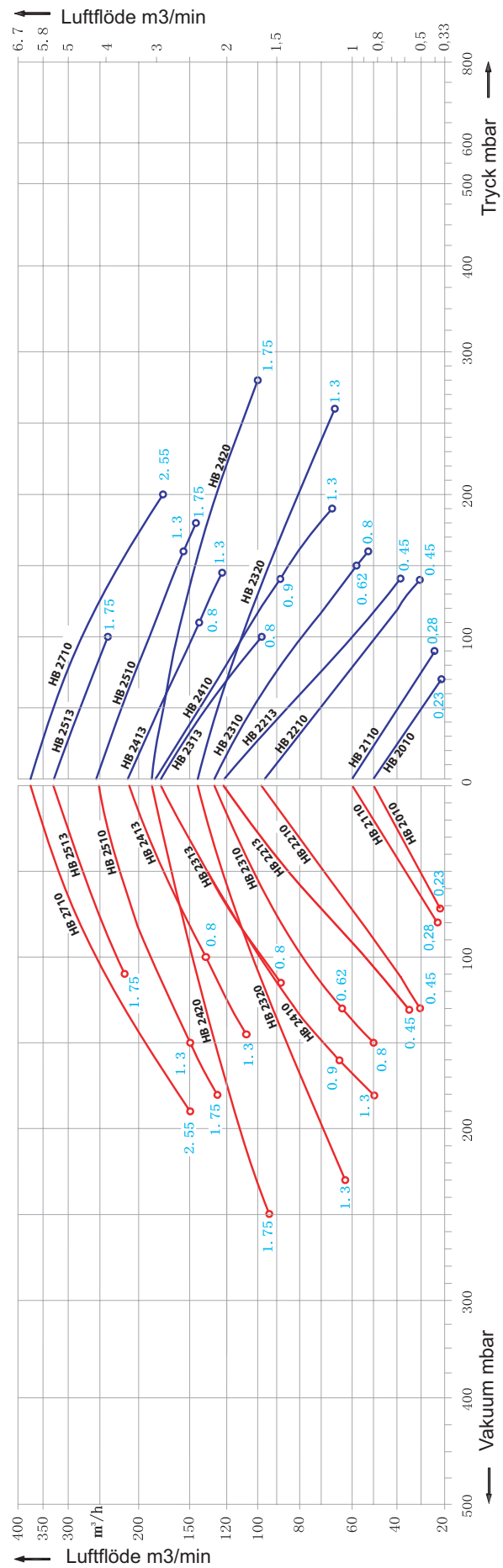

Ventilation

Axialfläktar

Radialfläktar

Punktstug

EX-Fläktar

Rök-/Brandgas

Sidokanal

Tillbehör

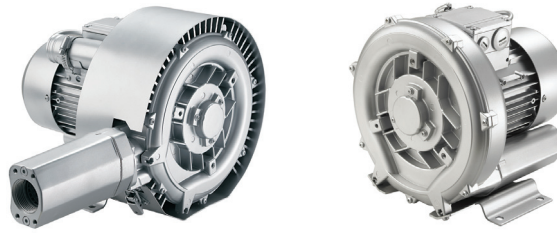

TYP	Frekvens Hz	Motoreffekt kW	Spänning V	Märkström A	Flöde max m3/h	Max vakuum mbar	Max tryck mbar	Ljud dB	Vikt KG
HB 2010-020T	50	0,2	200-240/345-415Y	1,0/0,6Y	40	-60	70	50	6
	60	0,23	220-275/380-480Y	1,0/0,6Y	55	-60	70	51	
HB 2110-025T	50	0,25	200-240/345-415Y	1,16/0,7Y	55	-80	80	51	7
	60	0,28	220-275/380-480Y	1,3/0,9Y	60	-80	80	52	
HB 2210-025T	50	0,25	200-240/345-415Y	2,1/1,2Y	80	-100	110	53	9
	60	0,29	220-275/380-480Y	2,0/1,15Y	98	-110	120	56	
HB 2210-040T	50	0,4	200-240/345-415Y	2,6/1,5Y	80	-120	130	53	10
	60	0,5	220-275/380-480Y	2,6/1,5Y	98	-150	160	56	
HB 2213-025T	50	0,25	200-240/345-415Y	2,1/1,2Y	105	-70	80	54	10
	60	0,29	220-275/380-480Y	1,7/1,0Y	120	-80	80	57	
HB 2213-040T	50	0,4	200-240/345-415Y	2,6/1,5Y	105	-120	130	54	11
	60	0,5	220-275/380-480Y	2,6/1,5Y	120	-150	150	57	
HB 2213-110T	50	1,1	200-240/345-415Y	3,8/2,2Y	105	-120	130	54	12
	60	1,3	220-275/380-480Y	3,8/2,2Y	120	-160	180	57	
HB 2220-070T	50	0,7	200-240/345-415Y	3,8/2,2Y	85	-210	240	55	15
	60	0,83	220-275/380-480Y	3,75/2,15Y	102	-250	250	61	

Mått

Typ	A	B	C	D	E	F	G	H	J	K	L	M	N	O	ØP	Q	ØR	S	U	V	V'	ØX	YxZ
HB 2010-020T	198	212	85	179	196	220	108	115	100	65	90	40	45	34	1"	60	8,5	2	M6x17	-	-	119	M6x15
HB 2110-025T	221	235	94	190	207	225	118	118	100	77	100	33	53	38	1"	64	8,5	2	M6x17	-	-	132	M6x15
HB 2210-025T	246	247	90	205	230	256	133	128	111	83	108	75	71	39	1 1/4"	64	10	2,5	M6x17	M16x1,5	M25x1,5	140	M6x15
HB 2210-037T	246	247	90	205	230	256	135	128	111	83	108	75	71	39	1 1/4"	64	10	2,5	M6x17	M16x1,5	M25x1,5	140	M6x15
HB 2213-025T	246	247	90	205	230	267	135	128	111	83	108	75	82	39	1 1/4"	64	10	2,5	M6x17	M16x1,5	M25x1,5	140	M6x15
HB 2213-040T	246	247	90	205	230	267	135	128	111	83	108	75	82	39	1 1/4"	64	10	2,5	M6x17	M16x1,5	M25x1,5	140	M6x15
HB 2213-110T	246	247	90	205	230	267	135	128	111	83	108	75	82	39	1 1/4"	64	10	2,5	M6x17	M16x1,5	M25x1,5	140	M6x15
HB 2220-070T	284	270	45	205	230	316	129	128	111	83	108	75	130	39	1 1/4"	64	10	2,5	M6x17	M25x1,5	M16x1,5	140	M6x15

HB 2010/2110/2210/2213/2310/2313

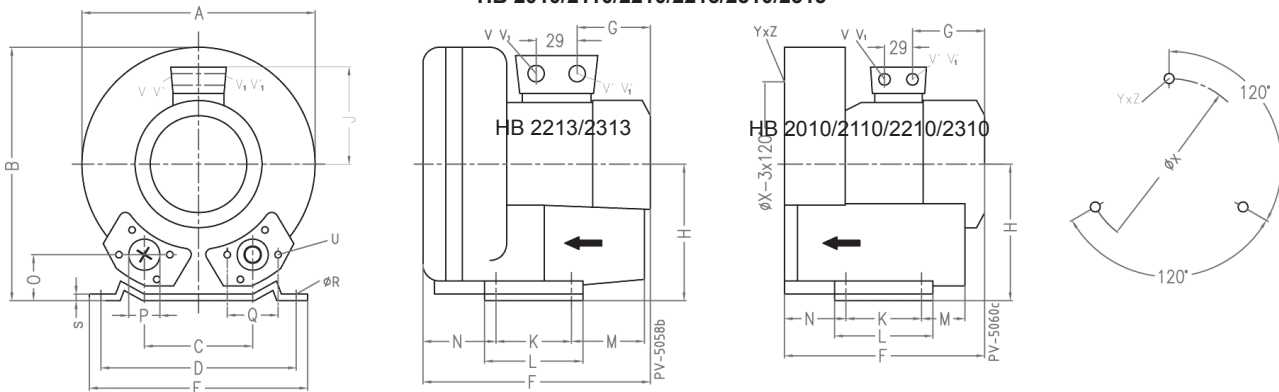

HB 2220/2320/2420

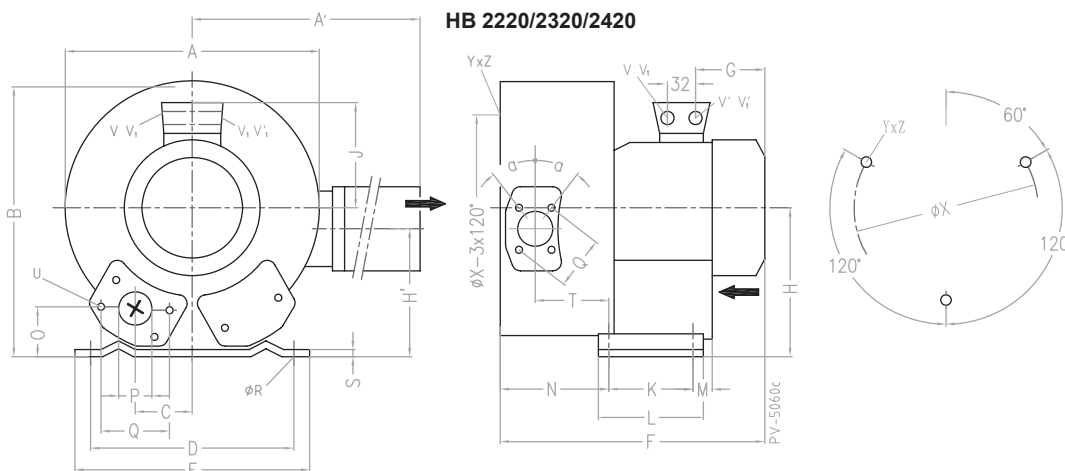

Flödesdiagram 50Hz

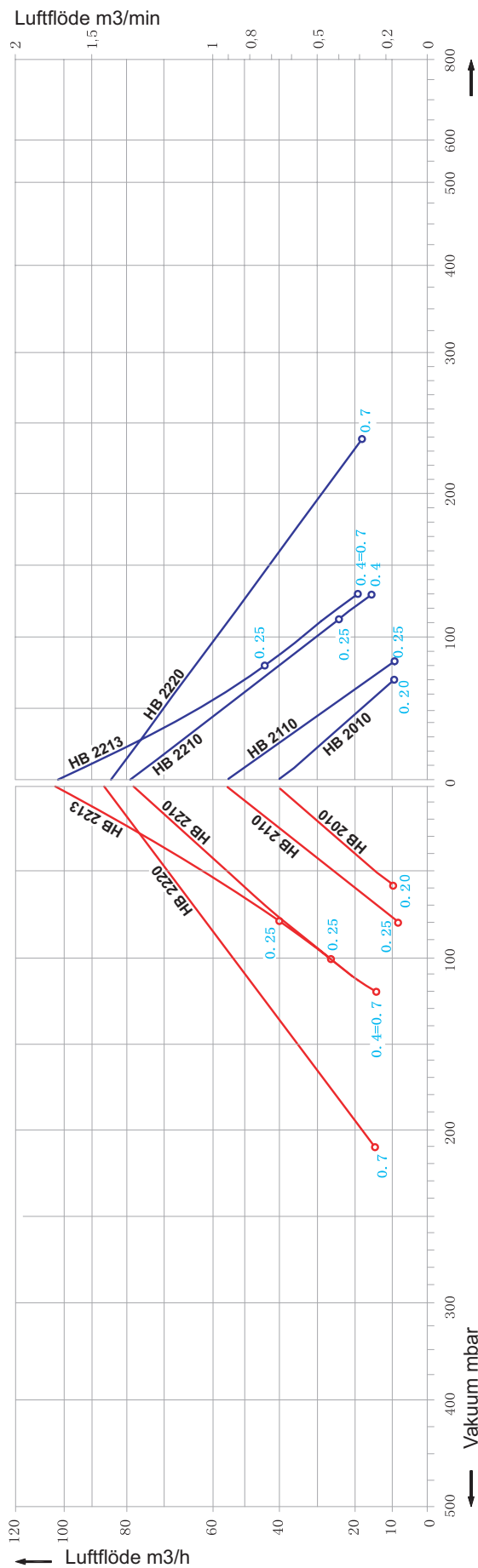

Flödesdiagram 60Hz

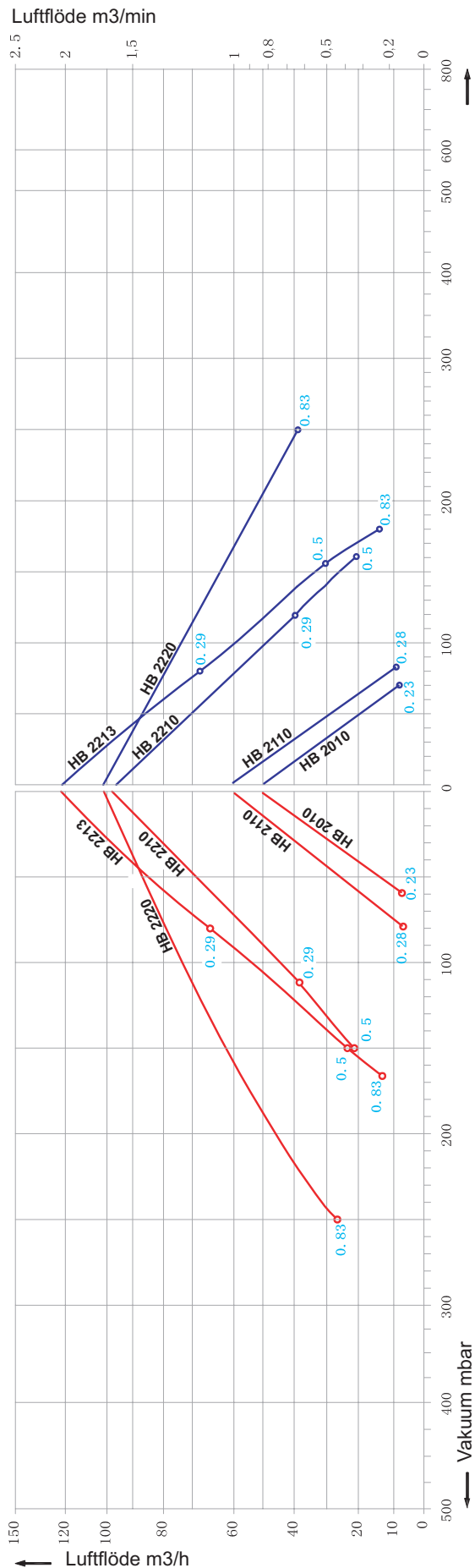

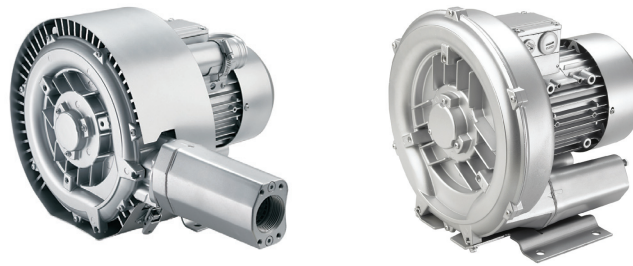

TYP	Frekvens Hz	Motoreffekt kW	Spänning V	Märkström A	Flöde max m3/h	Max vakuüm mbar	Max tryck mbar	Ljud dB	Vikt KG
HB 2310-055T	50	0,55	200-240/345-415Y	2,8/1,6Y	100	-120	130	55	11
	60	0,63	220-275/380-480Y	3,0/1,7Y	120	-120	140	57	
HB 2310-070T	50	0,7	200-240/345-415Y	3,8/2,2Y	100	-150	130	55	12
	60	0,83	220-275/380-480Y	3,8/2,2Y	120	-160	140	57	
HB 2313-055T	50	0,55	200-240/345-415Y	2,8/1,6Y	140	-60	60	56	12
	60	0,63	220-275/380-480Y	3,0/1,7Y	165	-40	40	58	
HB 2313-070T	50	0,7	200-240/345-415Y	3,8/2,2Y	140	-100	100	56	13
	60	0,83	220-275/380-480Y	3,8/2,2Y	165	-115	100	58	
HB 2320-085T	50	0,85	200-240/345-415Y	4,2/2,4Y	110	-200	230	58	17
	60	0,93	220-275/380-480Y	4,0/2,3Y	130	-240	240	60	
HB 2320-130T	50	1,3	200-240/345-415Y	5,7/3,3Y	110	-260	319	58	18
	60	1,5	220-275/380-480Y	6,0/3,5Y	130	-260	320	60	

Mått

Typ	A	B	C	D	E	F	G	H	J	K	L	M	N	O	ØP	Q	ØR	S	U	V	V'	ØX	YxZ
HB 2310-055T	268	272	93	205	230	260	135	141	111	83	108	82	69	41	1 1/4"	64	10	2,5	M6x17	M16x1,5	M25x1,5	160	M6x15
HB 2310-070T	268	272	93	205	230	260	135	141	111	83	108	82	69	41	1 1/4"	64	10	2,5	M6x17	M16x1,5	M25x1,5	160	M6x15
HB 2313-055T	268	272	93	205	230	276	135	141	111	83	108	82	85	41	1 1/4"	64	10	2,5	M6x17	M16x1,5	M25x1,5	160	M6x15
HB 2313-070T	268	272	93	205	230	260	135	141	111	83	108	82	85	41	1 1/4"	64	10	2,5	M6x17	M16x1,5	M25x1,5	160	M6x15
HB 2313-085T	268	272	93	205	230	260	135	141	111	83	108	82	85	41	1 1/4"	64	10	2,5	M6x17	M16x1,5	M25x1,5	160	M6x15
HB 2320-130T	293	286	47	205	230	354	160	141	120	83	108	82	138	41	1 1/4"	64	10	2,5	M6x17	M25x1,5	M16x1,5	160	M6x15

HB 2310/2313

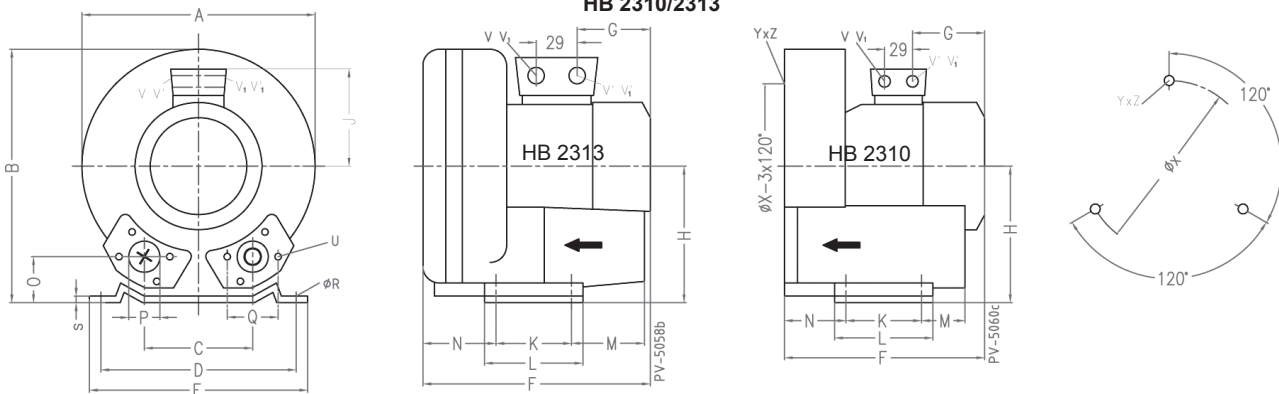

HB 2320

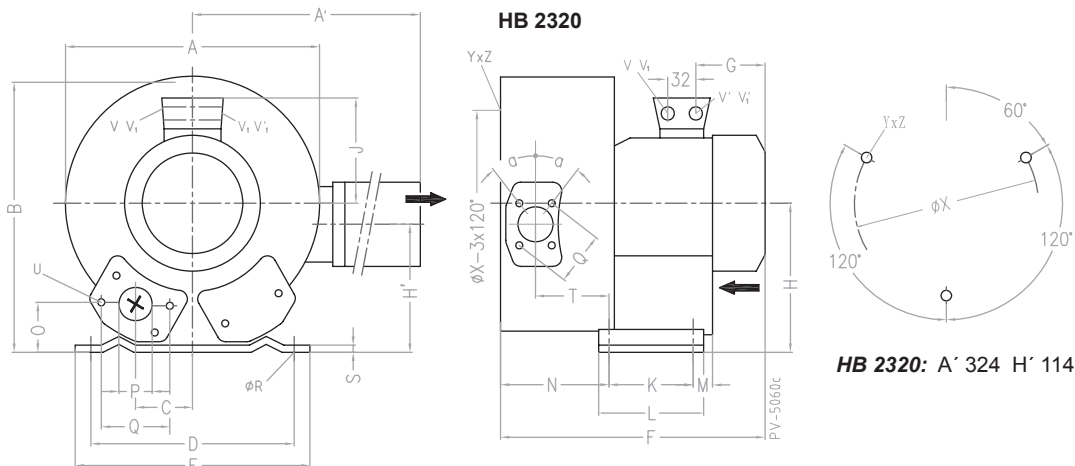

Flödesdiagram 50Hz

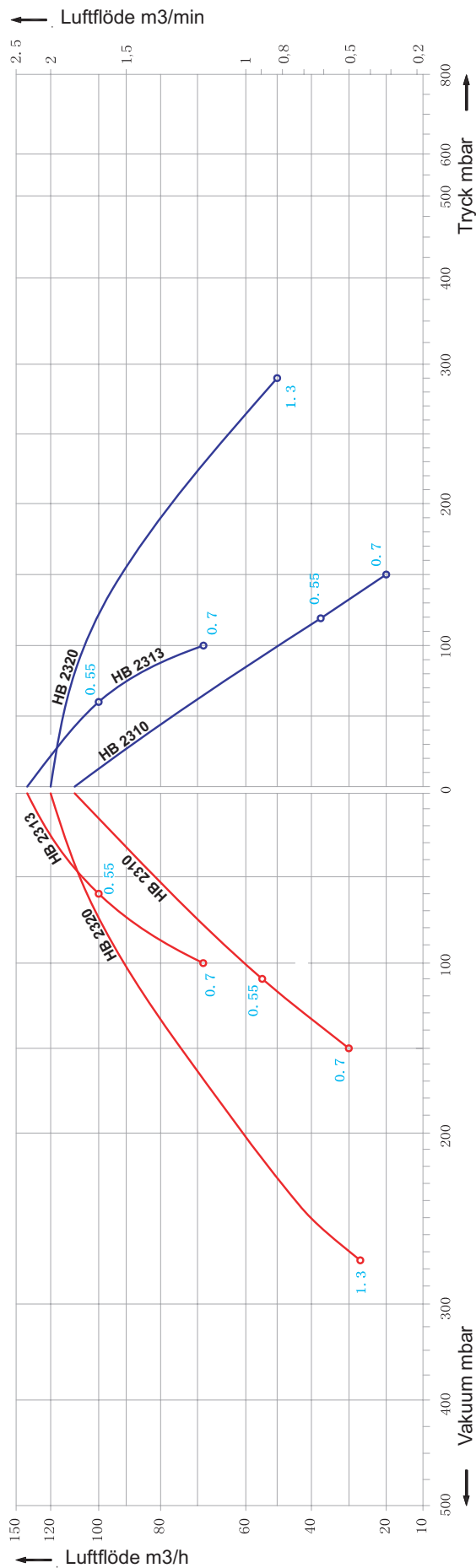

Flödesdiagram 60Hz

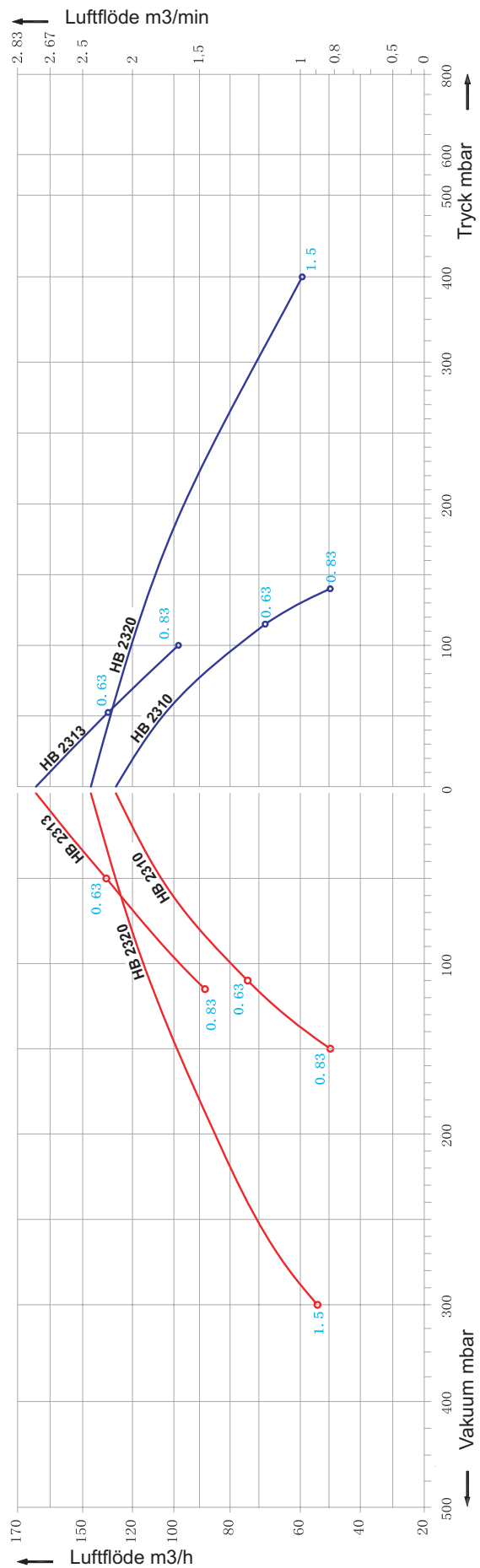

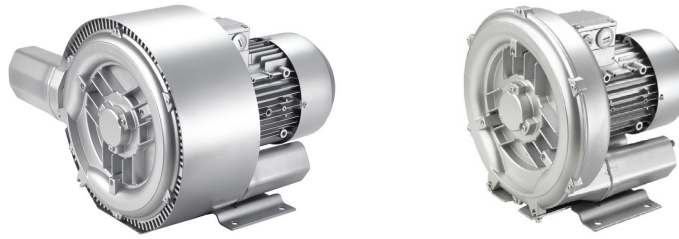

TYP	Frekvens	Motoreffekt	Spänning	Märkström	Flöde max	Max vakuum	Max tryck	Ljud	Vikt
	Hz	kW	V	A	m ³ /h	mbar	mbar	dB	KG
HB 2419-060T	50	0,6	200-240/345-415Y	2,8/1,6Y	140	-120	120	63	14
	60	0,85	220-275/380-480Y	3,6/2,1Y	175	-140	140	64	
HB 2410-070T	50	0,7	200-240/345-415Y	3,8/2,2Y	145	-120	120	63	13
	60	0,83	220-275/380-480Y	3,8/2,2Y	175	-130	130	64	
HB 2410-085T	50	0,85	200-240/345-415Y	4,0/2,3Y	145	-160	160	63	16
	60	0,95	220-275/380-480Y	3,85/2,25Y	175	-160	160	64	
HB 2410-130T	50	1,3	200-240/345-415Y	5,7/3,3Y	145	-170	200	63	17
	60	1,5	220-275/380-480Y	6,0/3,5Y	175	-210	220	64	
HB 2413-070T	50	0,7	200-240/345-415Y	3,8/2,2Y	180	-70	70	64	14
	60	0,83	220-275/380-480Y	3,8/2,2Y	210	-50	50	65	
HB 2413-085T	50	0,85	200-240/345-415Y	4,2/2,4Y	180	-120	120	64	17
	60	0,95	220-275/380-480Y	4,0/2,3Y	210	-90	70	65	
HB 2413-130T	50	1,3	200-240/345-415Y	6,6/3,8Y	180	-170	220	64	18
	60	1,5	220-275/380-480Y	6,9/4,0Y	210	-200	160	65	
HB 2420-160T	50	1,6	200-240/345-415Y	7,5/4,3Y	150	-280	280	66	25
	60	2,05	220-275/380-480Y	7,6/4,4Y	180	-320	310	69	
HB 2420-220T	50	2,2	200-240/345-415Y	9,7/5,6Y	150	-330	440	66	27
	60	2,55	220-275/380-480Y	10/5,8Y	180	-350	420	69	

Mått

Typ	A	B	C	D	E	F	G	H	J	K	L	M	N	O	ØP	Q	ØR	S	U	V	V'	ØX	YxZ
HB 2419-060T	286	302	115	225	255	311	160	154	120	95	130	70	75	46	1½"	72	12	3	M6x19	M25x1,5	M16x1,5	174	-
HB 2410-070T	286	302	115	225	255	269	135	154	111	95	130	70	75	46	1½"	72	12	3	M6x19	M16x1,5	M25x1,5	174	-
HB 2410-085T	286	302	115	225	255	292	160	154	120	95	130	70	75	46	1½"	72	12	3	M6x19	M16x1,5	M25x1,5	174	-
HB 2410-130T	286	302	115	225	255	292	160	154	120	95	130	70	75	46	1½"	72	12	3	M6x19	M16x1,5	M25x1,5	174	-
HB 2413-070T	286	302	115	225	255	288	135	154	111	95	130	70	75	46	1½"	72	12	3	M6x19	M16x1,5	M25x1,5	174	-
HB 2413-085T	286	302	115	225	255	311	160	154	120	95	130	70	75	46	1½"	72	12	3	M6x19	M16x1,5	M25x1,5	174	-
HB 2413-130T	286	302	115	225	255	311	160	154	120	95	130	70	75	46	1½"	72	12	3	M6x19	M16x1,5	M25x1,5	174	-
HB 2420-160T	322	315	58	225	255	401	191	154	128	95	130	73	151	45	1½"	72	12	3	M6x19	M25x1,5	M16x1,5	174	M6x15
HB 2420-220T	322	315	58	225	255	401	191	154	128	95	130	73	151	45	1½"	72	12	3	M6x19	M16x1,5	M25x1,5	174	M6x15

HB 2410/2413/2419

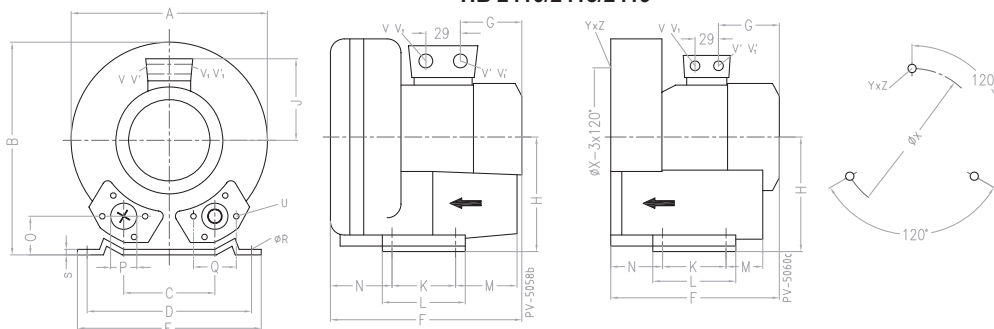

HB 2420

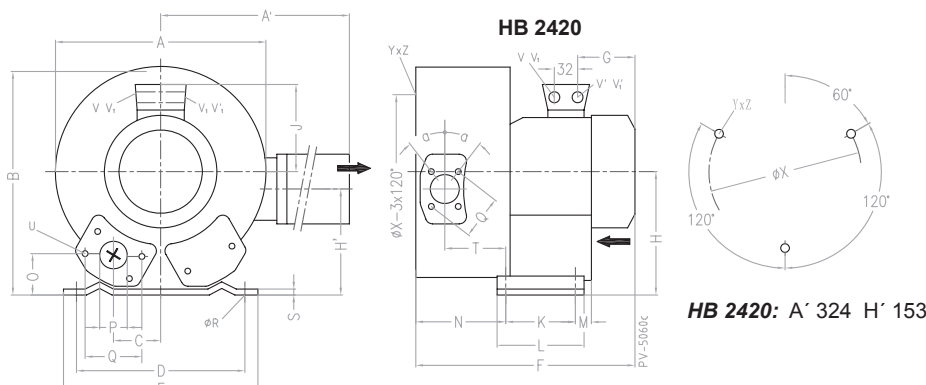

Flödesdiagram 50Hz

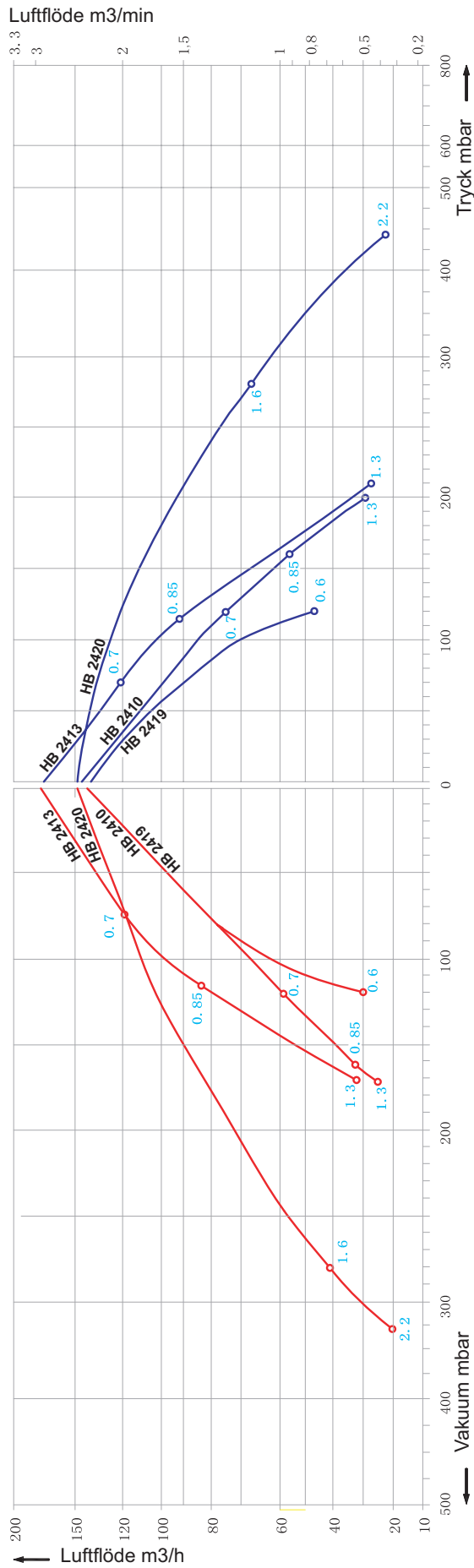

Flödesdiagram 60Hz

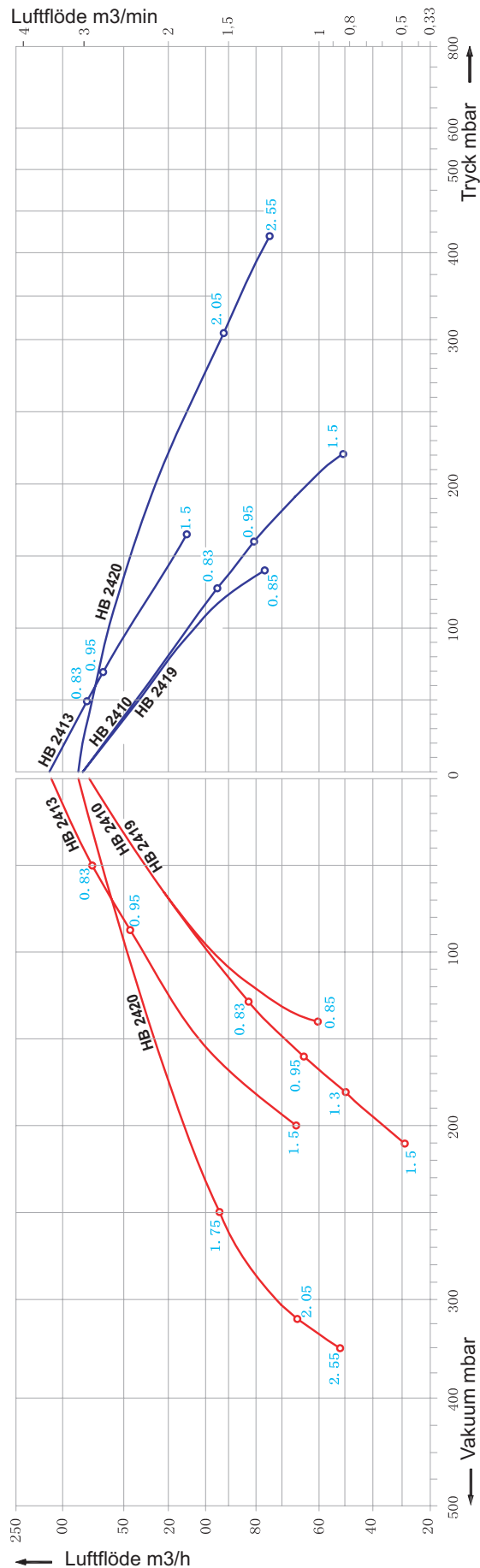



TYP	Frekvens Hz	Motoreffekt kW	Spänning V	Märkström A	Flöde max m ³ /h	Max vakuüm mbar	Max tryck mbar	Ljud dB	Vikt KG
HB 2519-110T	50	1,1	200-240/345-415Y	5,7/3,3Y	210	-130	150	64	23
	60	1,7	220-275/380-480Y	6,0/3,5Y	255	-180	210	70	
HB 2510-075T	50	0,75	200-240/345-415Y	3,65/2,1Y	210	-110	100	64	20
	60	0,86	220-275/380-480Y	3,6/2,1Y	255	-80	70	70	
HB 2510-130T	50	1,3	200-240/345-415Y	6,6/3,8Y	210	-170	170	64	22
	60	1,5	220-275/380-480Y	6,9/4,0Y	255	-150	140	70	
HB 2510-160T	50	1,6	200-240/345-415Y	7,5/4,3Y	210	-200	190	64	23
	60	2,05	220-275/380-480Y	7,6/4,4Y	255	-220	210	70	
HB 2510-220T	50	2,2	200-240/345-415Y	9,7/5,6Y	210	-220	270	64	25
	60	2,55	220-275/380-480Y	10,3/6,0Y	255	-260	290	70	
HB 2513-085T	50	0,85	200-240/345-415Y	4,0/2,3Y	270	-40	40	65	21
	60	0,95	220-275/380-480Y	4,2/2,4Y	330	-40	40	71	
HB 2513-130T	50	1,3	200-240/345-415Y	6,6/3,8Y	270	-100	100	65	23
	60	1,5	220-275/380-480Y	6,9/4,0Y	330	-70	50	71	
HB 2513-160T	50	1,6	200-240/345-415Y	7,5/4,3Y	270	-150	150	65	24
	60	2,05	220-275/380-480Y	7,6/4,4Y	330	-150	130	71	
HB 2513-220T	50	2,2	200-240/345-415Y	9,7/5,6Y	270	-220	230	65	26
	60	2,55	220-275/380-480Y	10,5,8Y	330	-230	210	71	
HB 2520-300T	50	3	200-240/345-415Y	12,5/7,2Y	230	-340	410	72	40
	60	3,45	220-275/380-480Y	12,6/7,3Y	275	-380	360	74	
HB 2520-400T	50	4	345-415/ 600-720Y	10/5,8Y	230	-390	490	72	44
	60	4,6	345-415/ 600-720Y	9,9/5,71Y	275	-410	480	74	

Mått

Typ	A	B	C	D	E	F	G	H	J	K	L	M	N	O	ØP	Q	ØR	S	U	V	V'	ØX	YxZ
HB 2519-110T	334	337	120	260	295	365	191	175	128	115	155	96	87	48	55	83	14	4	M8x17	M16x1,5	M25x1,5	200	M8x20
HB 2510-075T	334	337	120	260	295	314	160	175	120	115	155	96	87	48	55	83	14	4	M8x17	M16x1,5	M25x1,5	200	M8x20
HB 2510-130T	334	337	120	260	295	314	160	175	120	115	155	96	87	48	55	83	14	4	M8x17	M16x1,5	M25x1,5	200	M8x20
HB 2510-160T	334	337	120	260	295	346	191	175	128	115	155	96	87	48	55	83	14	4	M8x17	M16x1,5	M25x1,5	200	M8x20
HB 2510-220T	334	337	120	260	295	346	191	175	128	115	155	96	87	48	55	83	14	4	M8x17	M16x1,5	M25x1,5	200	M8x20
HB 2513-085T	334	337	120	260	295	334	160	175	120	115	155	96	87	48	55	83	14	4	M8x17	M16x1,5	M25x1,5	200	M8x20
HB 2513-130T	334	337	120	260	295	334	160	175	120	115	155	96	87	48	55	83	14	4	M8x17	M16x1,5	M25x1,5	200	M8x20
HB 2513-160T	334	337	120	260	295	365	191	175	128	115	155	96	87	48	55	83	14	4	M8x17	M16x1,5	M25x1,5	200	M8x20
HB 2513-220T	334	337	120	260	295	365	191	175	128	115	155	96	87	48	55	83	14	4	M8x17	M16x1,5	M25x1,5	200	M8x20
HB 2520-300T	372	371	60	260	295	465	190	175	135	115	155	98	171	48	55	83	14	4	M8x17	M32x1,5	M32x1,5	200	M8x20
HB 2520-400T	372	371	60	260	295	499	224	175	135	115	155	98	171	48	55	83	14	4	M8x17	M32x1,5	M32x1,5	200	M8x20

HB 2510/2513/2519

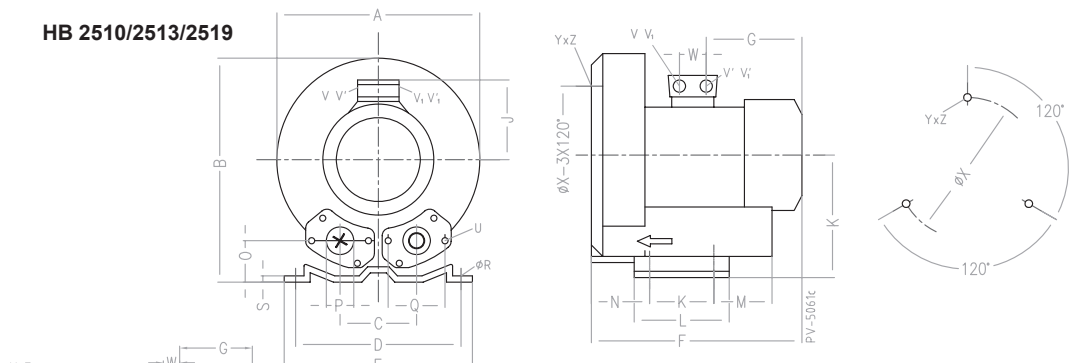

HB 2520

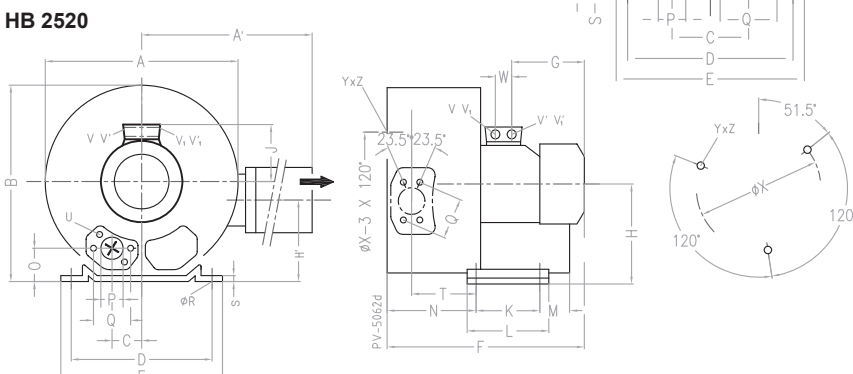

Flödesdiagram 50Hz

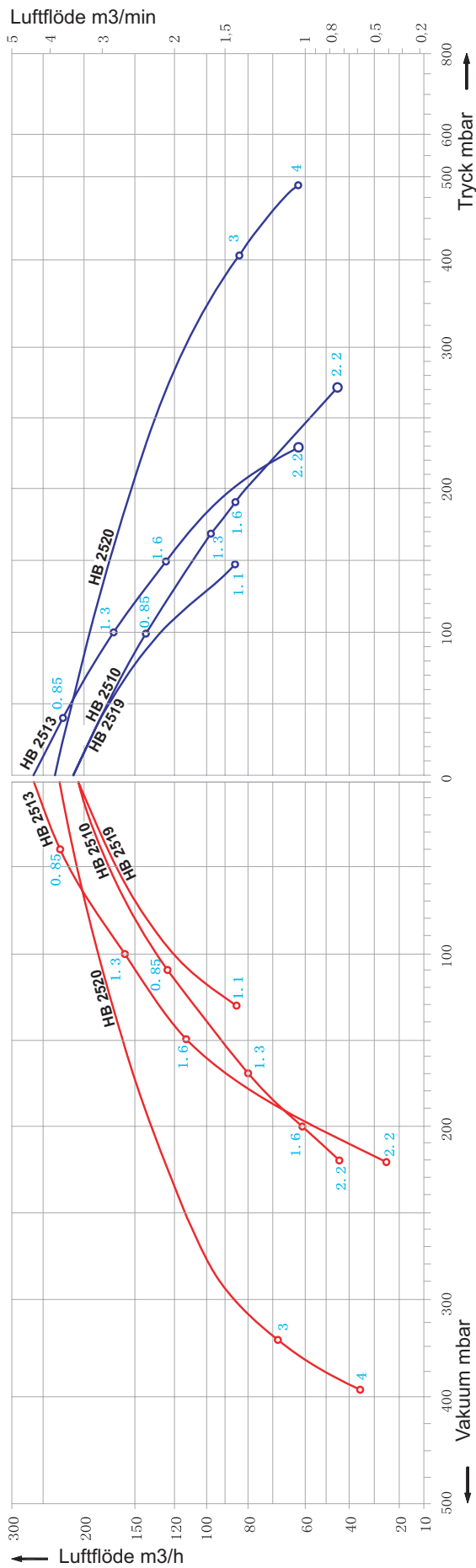

Flödesdiagram 60Hz

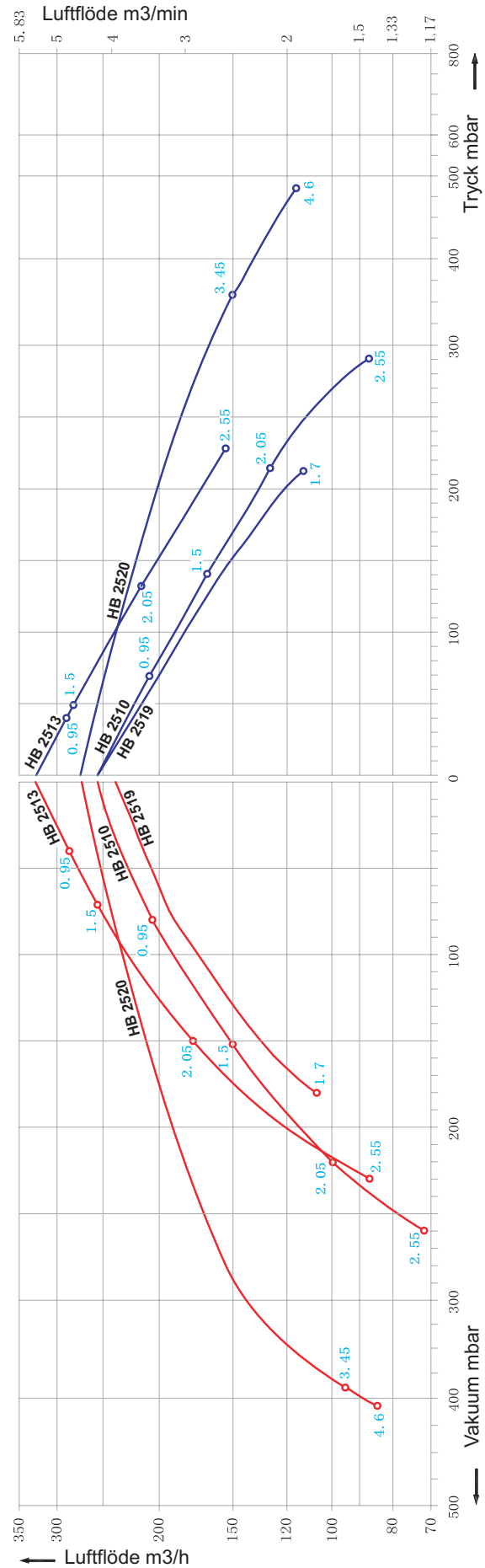

Ventilation

Axialfläktar

Radialfläktar

Punktutug

EX-Fläktar

Rök-/Brandgas

Sidokanal

Tillbehör



TYP	Frekvens Hz	Motoreffekt kW	Spänning V	Märkström A	Flöde max m3/h	Max vakuüm mbar	Max tryck mbar	Ljud dB	Vikt KG
HB 2610-160T	50	1,6	200-240/345-415Y	8,5/4,9Y	265	-170	180	68	25
	60	2,05	220-275/380-480Y	8,8/5,1Y	315	-180	190	70	
HB 2610-220T	50	2,2	200-240/345-415Y	9,7/5,6Y	265	-235	220	69	28
	60	2,55	220-275/380-480Y	10,3/6,0Y	315	-245	230	72	
HB 2610-300T	50	3	200-240/345-415Y	12,5/7,2Y	265	-280	280	69	34
	60	3,45	220-275/380-480Y	12,6/7,3Y	315	-260	270	72	
HB 2613-160T	50	1,6	200-240/345-415Y	8,5/4,9Y	345	-125	125	70	26
	60	2,05	220-275/380-480Y	8,8/5,1Y	415	-105	130	73	
HB 2613-220T	50	2,2	200-240/345-415Y	9,7/5,6Y	345	-200	195	70	29
	60	2,55	220-275/380-480Y	10,3/6,0Y	415	-170	195	73	
HB 2613-300T	50	3	200-240/345-415Y	12,5/7,2Y	345	-240	220	70	35
	60	3,45	220-275/380-480Y	12,6/7,3Y	415	-210	220	73	

Mått

Typ	A	B	C	D	E	F	G	H	J	K	L	M	N	O	ØP	Q	ØR	S	U	V	V'	ØX	YxZ
HB 2610-160T	360	366	122	284	325	354	191	192	128	140	180	64	74	56	56	93	13	4,5	M8x17	M16x1,5	M25x1,5	226	M8x20
HB 2610-220T	360	366	122	284	325	354	191	192	128	140	180	64	74	56	56	93	13	4,5	M8x17	M16x1,5	M25x1,5	226	M8x20
HB 2610-300T	360	366	122	284	325	385	188	192	135	140	180	64	74	56	56	93	13	4,5	M8x17	M32x1,5	M32x1,5	226	M8x20
HB 2613-160T	360	366	122	284	325	372	191	192	128	140	180	64	74	56	56	93	13	4,5	M8x17	M16x1,5	M25x1,5	226	M8x20
HB 2613-220T	360	366	122	284	325	372	191	192	128	140	180	64	74	56	56	93	13	4,5	M8x17	M16x1,5	M25x1,5	226	M8x20
HB 2613-300T	360	366	122	284	325	403	188	192	135	140	180	64	74	56	56	93	13	4,5	M8x17	M32x1,5	M32x1,5	226	M8x20

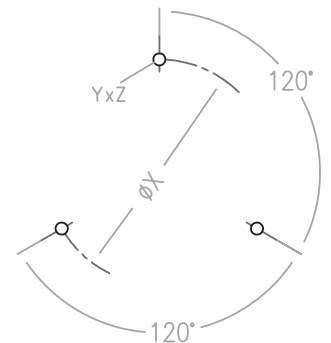
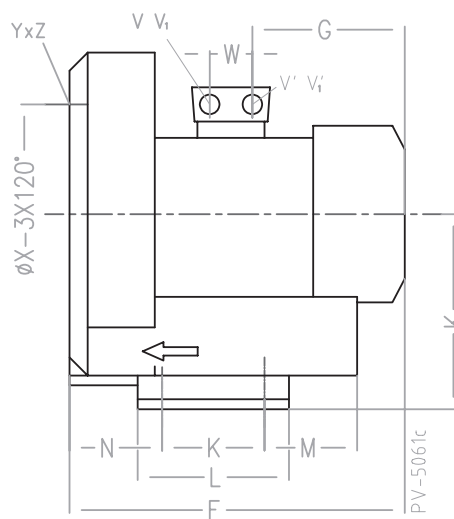
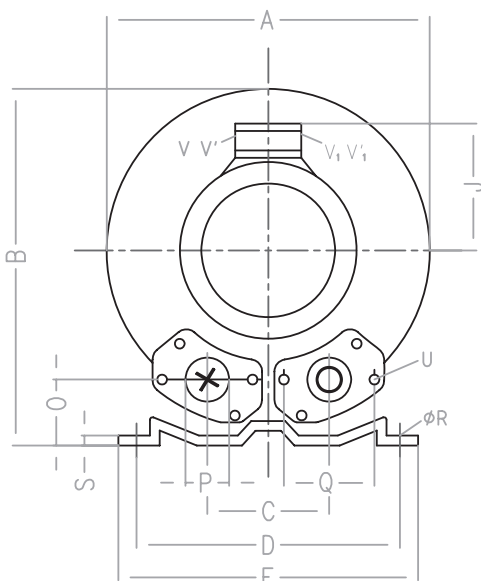

Flödesdiagram 50Hz

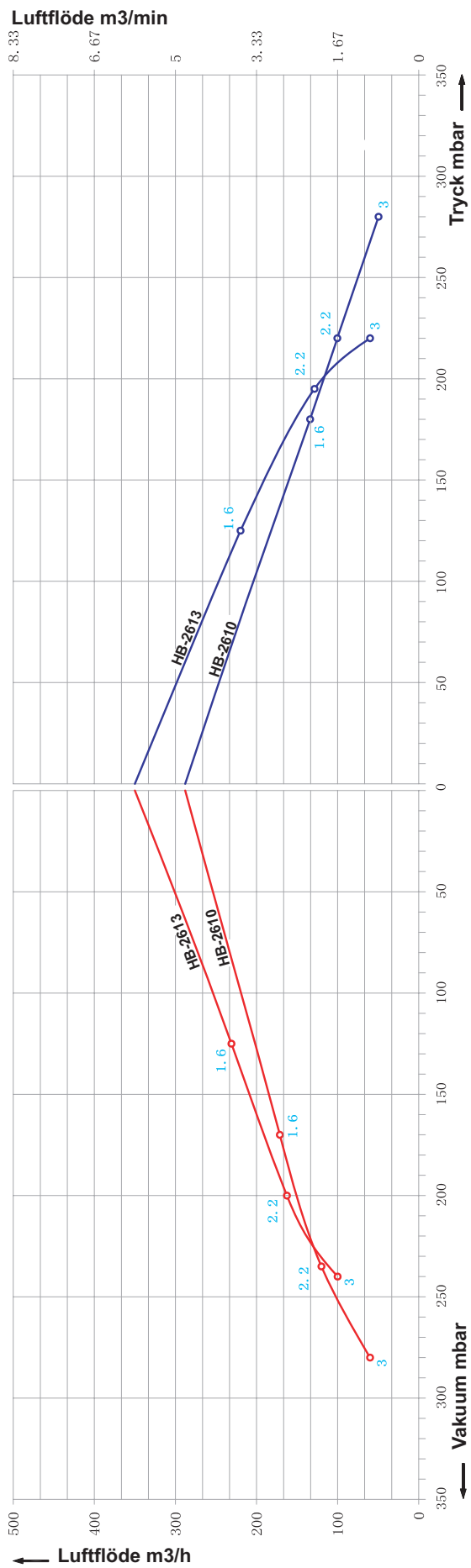

Flödesdiagram 60Hz

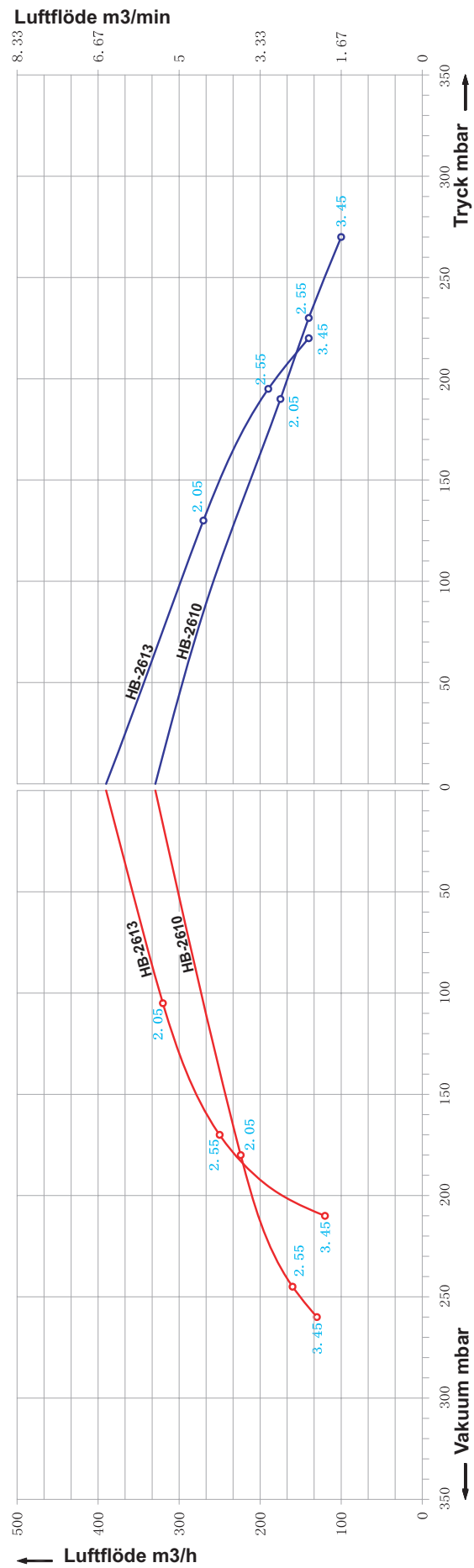

Ventilation

Axialfläktar

Radialfläktar

Punktutslug

EX-Fläktar

Rök-/Brandgas

Sidokanal

Tillbehör



TYP	Frekvens Hz	Motoreffekt kW	Spänning V	Märkström A	Flöde max m ³ /h	Max vakuum mbar	Max tryck mbar	Ljud dB	Vikt KG
HB 2719-220T	50	2,2	200-240/345-415Y	12,5/7,2Y	320	-160	200	69	36
	60	2,55	220-275/380-480Y	12,6/7,3Y	370	-240	250	72	
HB 2710-160T	50	1,6	200-240/345-415Y	8,5/4,9Y	318	-160	150	69	27
	60	2,05	220-275/380-480Y	8,8/5,1Y	376	-160	150	72	
HB 2710-220T	50	2,2	200-240/345-415Y	9,7/5,6Y	318	-210	200	69	30
	60	2,55	220-275/380-480Y	10,3/6,0Y	376	-210	200	72	
HB 2710-300T	50	3	200-240/345-415Y	12,5/7,2Y	318	-270	290	69	36
	60	3,45	220-275/380-480Y	12,6/7,3Y	376	-250	230	72	
HB 2710-400T	50	4	345-415/ 600-720Y	9,0/5,2Y	318	-290	390	69	40
	60	4,6	345-415/ 600-720Y	9,0/5,2Y	376	-330	330	72	
HB 2713-160T	50	1,6	200-240/345-415Y	8,5/4,9Y	420	-100	100	70	29
	60	2,05	220-275/380-480Y	8,8/5,1Y	500	-110	80	73	
HB 2713-220T	50	2,2	200-240/345-415Y	9,7/5,6Y	420	-170	170	70	32
	60	2,55	220-275/380-480Y	10,3/6,0Y	500	-160	120	73	
HB 2713-300T	50	3	200-240/345-415Y	12,5/7,2Y	420	-220	220	70	37
	60	3,45	220-275/380-480Y	12,6/7,3Y	500	-200	190	73	
HB 2713-400T	50	4	345-415/ 600-720Y	9,0/5,2Y	420	-260	310	70	43
	60	4,6	345-415/ 600-720Y	9,0/5,2Y	500	-260	280	73	

Mått

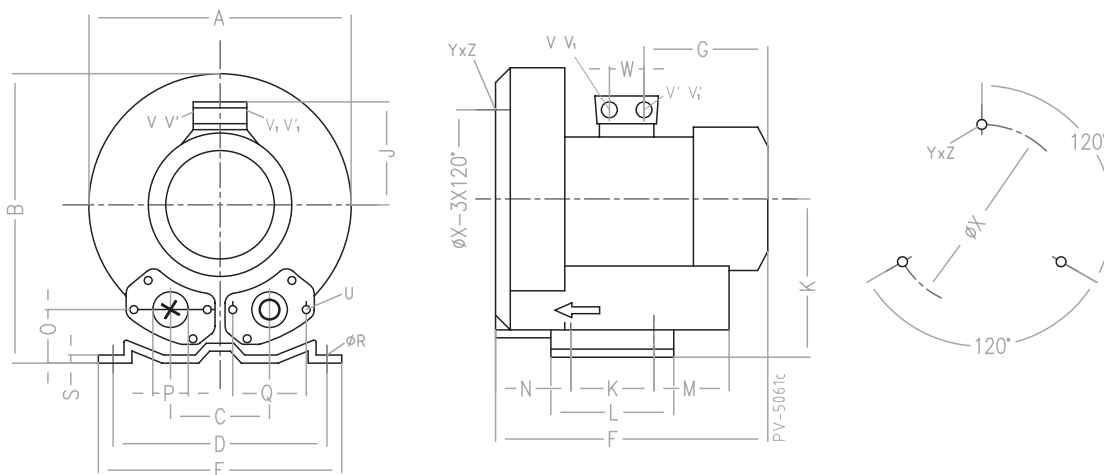

Typ	A	B	C	D	F	G	H	J	M	N	O	ØP	Q	ØR	V1	V'	YxZ	ØX	W
HB 2710-160T	382	384	125	290	377	191	197	128	84	109	54	55	83	15	M25x1,5	M16x1,5	M10x20	240	29
HB 2710-220T	382	384	125	290	377	191	197	128	84	109	54	55	83	15	M25x1,5	M16x1,5	M10x20	240	29
HB 2710-300T	382	384	125	290	409	188	197	135	84	109	54	55	83	15	M32x1,5	M32x1,5	M10x20	240	42
HB 2710-400T	382	384	125	290	432	209	197	148	84	109	54	55	83	15	M32x1,5	M32x1,5	M10x20	240	42
HB 2713-160T	382	384	125	290	387	191	197	128	84	109	54	55	83	15	M25x1,5	M16x1,5	M10x20	240	29
HB 2713-220T	382	384	125	290	387	191	197	128	84	109	54	55	83	15	M25x1,5	M16x1,5	M10x20	240	29
HB 2713-300T	382	384	125	290	419	189	197	135	84	109	54	55	83	15	M32x1,5	M32x1,5	M10x20	240	42
HB 2713-400T	382	384	125	290	432	209	197	148	84	109	54	55	83	15	M32x1,5	M32x1,5	M10x20	240	42
HB 2719-220T	382	384	125	290	377	185	197	128	84	109	54	55	83	15	M25x1,5	M16x1,5	M10x20	240	29

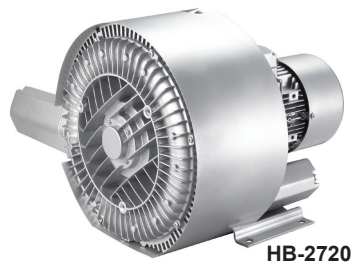
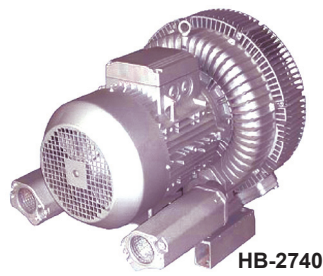

TYP	Frekvens	Motoreffekt	Spänning	Märkström	Flöde max	Max vakuum	Max tryck	Ljud	Vikt
	Hz	kW	V	A	m ³ /h	mbar	mbar	dB	KG
HB 2720-220T	50	2,2	200-240/345-415Y	9,7/5,6Y	320	-220	210	73	43
	60	2,55	220-275/380-480Y	10,6/6,0Y	380	-170	150	76	
HB 2720-300T	50	3	200-240/345-415Y	12,5/7,2Y	320	-280	260	73	48
	60	3,45	220-275/380-480Y	12,6/7,3Y	380	-230	200	76	
HB 2720-430T	50	4,3	345-415/ 600-720Y	10,5/2Y	320	-360	380	73	54
	60	4,6	345-415/ 600-720Y	10,4/6,0Y	380	-350	320	76	
HB 2720-550T	50	5,5	345-415/ 600-720Y	13,3/7,7Y	320	-440	500	73	66
	60	6,3	345-415/ 600-720Y	13,3/7,7Y	380	-440	500	76	
HB 2720-750T	50	7,5	345-415/ 600-720Y	16,7/9,6Y	320	-440	570	73	73
	60	8,6	345-415/ 600-720Y	17,3/10Y	380	-460	660	76	
HB 2740-400T	50	4	345-415/ 600-720Y	9/5,2Y	500	-150	140	74	54
	60	4,6	345-415/ 600-720Y	13,3/7,7Y	600	-100	90	78	
HB 2740-550T	50	5,5	345-415/ 600-720Y	13,3/7,7Y	500	-240	260	74	69
	60	6,3	345-415/ 600-720Y	13,3/7,7Y	600	-210	200	78	
HB 2740-750T	50	7,5	345-415/ 600-720Y	16,7/9,6Y	500	-240	320	74	75
	60	8,6	345-415/ 600-720Y	17,3/10Y	600	-270	300	78	

Mått HB 2720

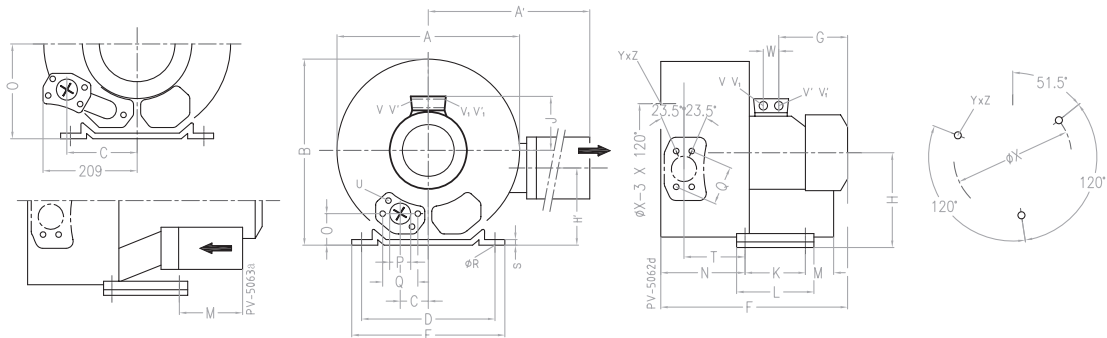

Typ	A	A'	B	C	D	E	F	G	H	H'	J	K	L	M	N	O	ØP	Q	ØR	S	T	V	ØX	YxZ
HB 2720-220T	426	426	410	63	290	325	473	191	197	162	128	140	180	84	205	53	55	83	15	4,5	130	M25x1,5	240	M10x20
HB 2720-300T	426	426	410	63	290	325	496	188	197	162	135	140	180	84	205	53	55	83	15	4,5	130	M32x1,5	240	M10x20
HB 2720-430T	426	426	410	63	290	325	526	209	197	162	148	140	180	84	205	53	55	83	15	4,5	130	M32x1,5	240	M10x20
HB 2720-550T	426	426	410	154	290	325	571	226	197	162	167	140	180	200	205	53	55	83	15	4,5	130	M32x1,5	240	M10x20
HB 2720-750T	426	426	410	154	290	325	571	226	197	162	167	140	180	200	205	53	55	83	15	4,5	130	M32x1,5	240	M10x20

Mått HB 2740

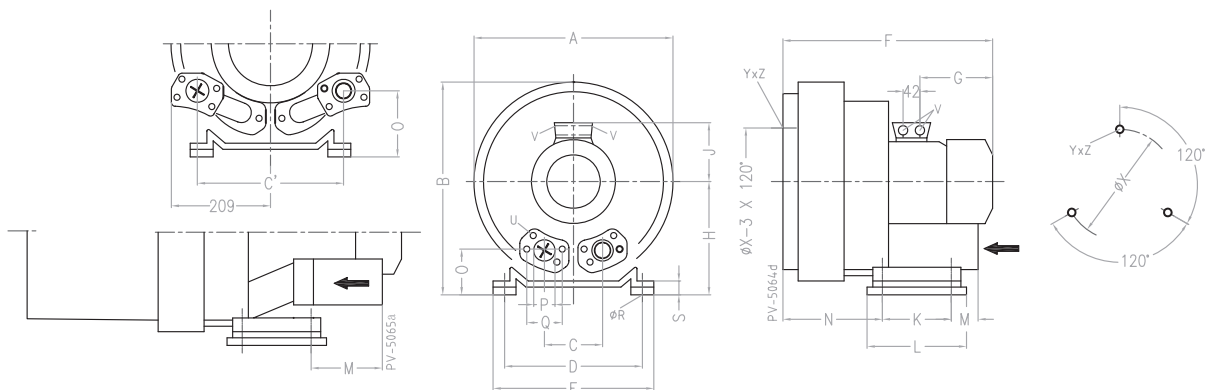

Typ	A	B	C	C'	D	E	F	G	H	J	K	L	M	N	O	ØP	Q	ØR	S	ØX	V	YxZ
HB 2740-400T	420	410	125	-	290	325	526	209	197	148	140	180	84	205	153	55	83	15	65	240	M32x1,5	M10x20
HB 2740-550T	420	410	-	308	290	325	571	226	257	167	140	180	200	205	153	55	83	15	65	240	M32x1,5	M10x20
HB 2740-750T	420	410	-	308	290	325	571	226	257	167	140	180	200	205	153	55	83	15	65	240	M32x1,5	M10x20

Flödesdiagram 50Hz

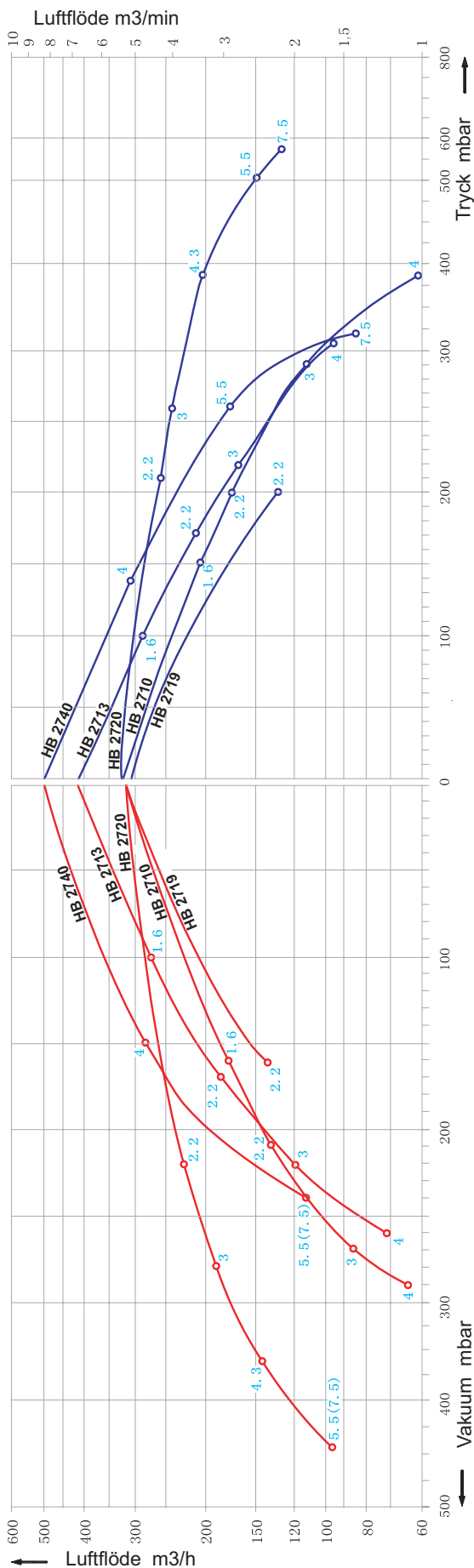

Flödesdiagram 60Hz

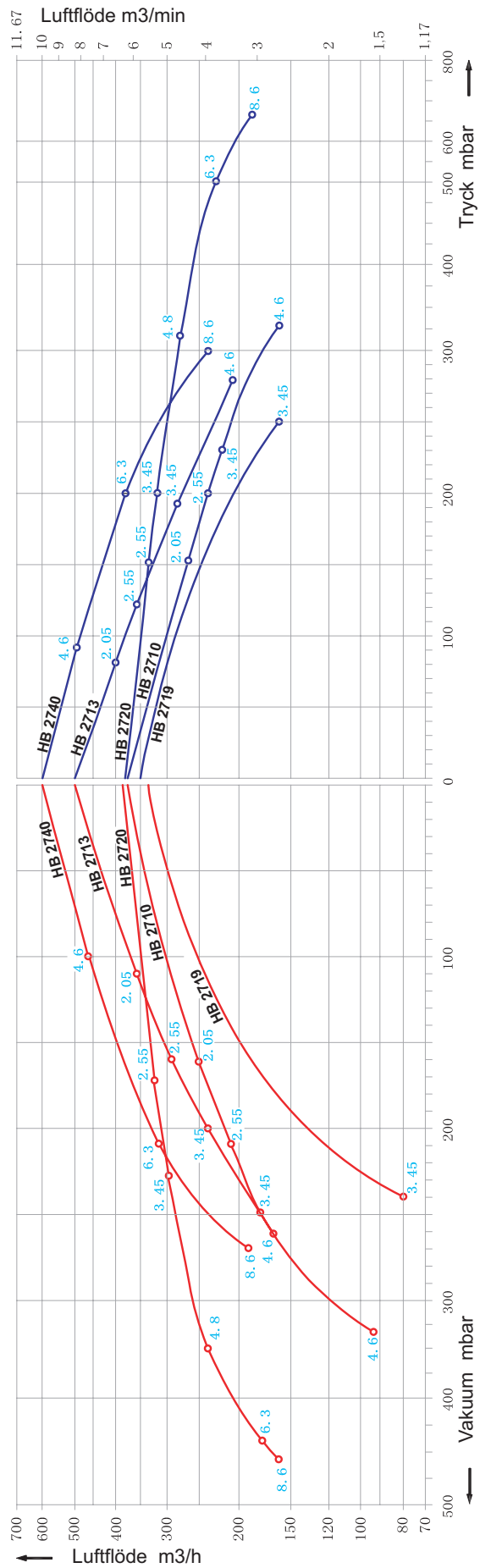

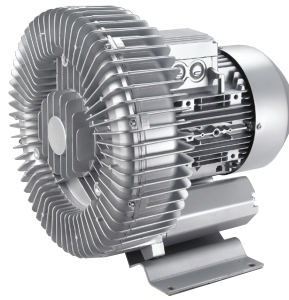

TYP	Frekvens Hz	Motoreffekt kW	Spänning V	Märkström A	Flöde max m3/h	Max vakuüm mbar	Max tryck mbar	Ljud dB	Vikt KG
HB 2810-400T	50	4	345-415/ 600-720Y	9,5/5,5Y	530	-200	200	70	54
	60	4,6	345-415/ 600-720Y	9,5/5,5Y	620	-160	160	74	
HB 2810-550T	50	5,5	345-415/ 600-720Y	12,9/7,4Y	530	-300	300	70	63
	60	6,3	345-415/ 600-720Y	12,9/7,4Y	620	-300	280	74	
HB 2810-750T	50	7,5	345-415/ 600-720Y	16,7/9,6Y	530	-320	430	70	66
	60	8,6	345-415/ 600-720Y	17,3/10Y	620	-350	400	74	
HB 2813-400T	50	4	345-415/ 600-720Y	9,5/5,5Y	700	-150	140	70	57
	60	4,6	345-415/ 600-720Y	9,5/5,5Y	840	-90	90	74	
HB 2813-550T	50	5,5	345-415/ 600-720Y	12,9/7,4Y	700	-200	180	70	66
	60	6,3	345-415/ 600-720Y	12,9/7,45Y	840	-180	180	74	
HB 2813-750T	50	7,5	345-415/ 600-720Y	16,7/9,6Y	700	-270	260	70	69
	60	8,6	345-415/ 600-720Y	17,3/10Y	840	-270	260	74	

Mått HB 2810 -2813

Typ	A	B	B'	C	D	E	F	F'	G	H	J	K	L	M	N	O	ØP	ØR	S	V	YxZ	ØX	W
HB 2810-400T	451	461	509	152	356	394	433	450	230	240	148	170	217	140	124	65	2½"	15	6	4*M32x1,5	M12*20	286	42
HB 2810-550T	451	461	509	152	356	394	433	477	226	240	167	170	217	140	124	65	2½"	15	6	4*M32x1,5	M12*20	286	42
HB 2810-750T	451	461	509	152	356	394	433	477	226	240	167	170	217	140	124	65	2½"	15	6	4*M32x1,5	M12*20	286	42
HB 2813-400T	451	461	509	152	356	394	449	466	230	240	148	170	217	139	164	65	2½"	15	6	4*M32x1,5	M12*20	286	42
HB 2813-550T	451	461	509	152	356	394	449	492	247	240	167	170	217	139	164	65	2½"	15	6	4*M32x1,5	M12*20	286	42
HB 2813-750T	451	461	509	152	356	394	449	492	247	240	167	170	217	139	164	65	2½"	15	6	4*M32x1,5	M12*20	286	42

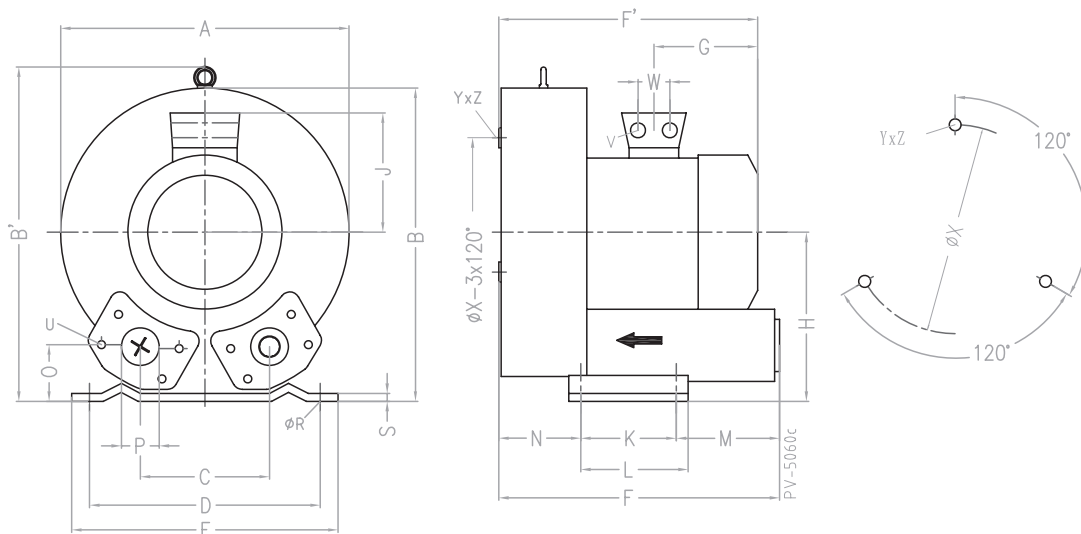

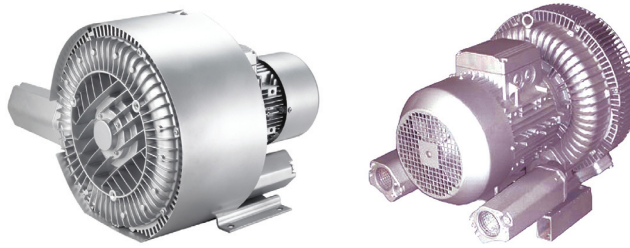

TYP	Frekvens	Motoreffekt	Spänning	Märkström	Flöde max	Max vakuüm	Max tryck	Ljud	Vikt
	Hz	kW	V	A	m ³ /h	mbar	mbar	dB	KG
HB 2820-550T	50	5,5	345-415/ 600-720Y	13,3/7,7Y	520	-240	240	74	83
	60	6,3	345-415/ 600-720Y	13,3/7,7Y	620	-170	160	78	
HB 2820-750T	50	7,5	345-415/ 600-720Y	16,7/9,6Y	520	-400	400	74	86
	60	8,6	345-415/ 600-720Y	17,3/10Y	620	-360	330	78	
HB 2820-1100T	50	11	345-415/ 600-720Y	28/16,2Y	520	-430	600	74	104
	60	12,6	345-415/ 600-720Y	29/16,7Y	620	-460	600	78	
HB 2820-1500T	50	15	345-415/ 600-720Y	32,5/18,8Y	520	-460	670	74	120
	60	17,3	345-415/ 600-720Y	34,5/19,9Y	620	-490	750	78	
HB 2840-750T	50	7,5	345-415/ 600-720Y	16,7/9,6Y	900	-200	180	74	91
	60	8,6	345-415/ 600-720Y	17,3/10Y	1050	-150	120	78	
HB 2840-1100T	50	11	345-415/ 600-720Y	28/16,2Y	900	-280	370	74	110
	60	12,6	345-415/ 600-720Y	29/16,7Y	1050	-310	350	78	

Mått HB 2820

Typ	A	B	B'	C	D	E	F	F'	G	H	J	K	L	N	O	ØP	ØR	S	W	V	ØX	YxZ
HB 2820-550T	500	490	509	76	356	394	545	589	226	240	167	170	217	236	65	2½"	15	6	42	4xM32x1,5	286	M12x20
HB 2820-750T	500	490	509	76	356	394	545	589	226	240	167	170	217	236	65	2½"	15	6	42	4xM32x1,5	286	M12x20
HB 2820-1100T	500	490	509	76	356	394	545	694	318	240	197	170	217	212	105	2½"	15	6	54	4xM40x1,5	286	M12x20
HB 2820-1500T	500	490	509	76	356	394	545	694	318	240	197	170	217	212	105	2½"	15	6	54	4xM40x1,5	286	M12x20

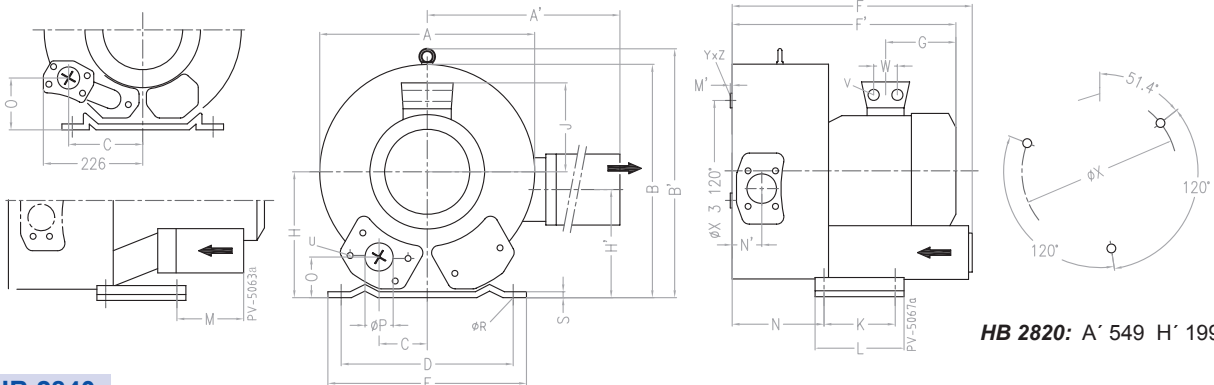

Mått HB 2840

Typ	A	B	C	C'	D	E	F	G	H	J	K	L	M	N	O	ØP	ØR	S	W	V	ØX	YxZ
HB 2840-750T	500	550	152	-	356	394	589	247	300	167	170	217	-	236	125	2½"	15	66	42	4xM32x1,5	286	M12x20
HB 2840-1100T	500	550	-	##	356	394	694	318	300	197	170	217	312	212	165	2½"	15	66	54	4xM40x1,5	286	M12x20

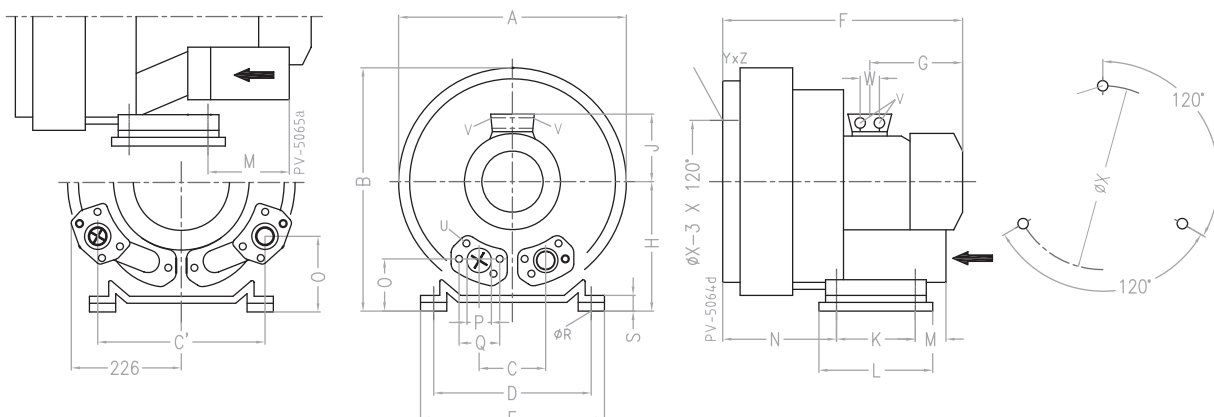

Flödesdiagram 50Hz

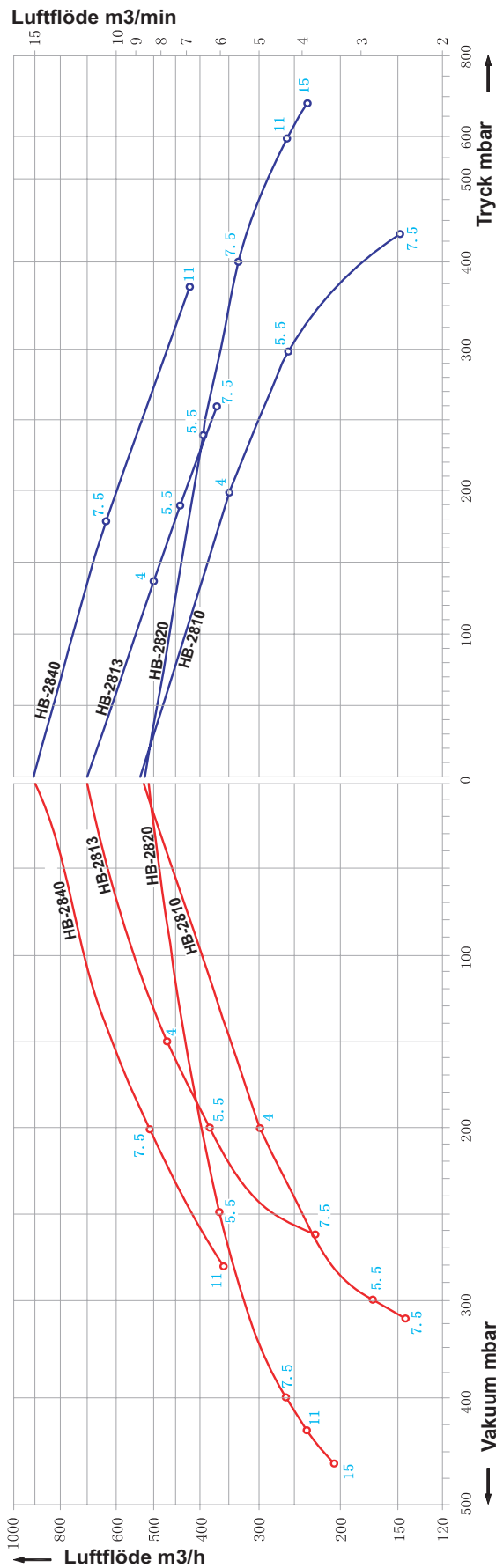

Flödesdiagram 60Hz

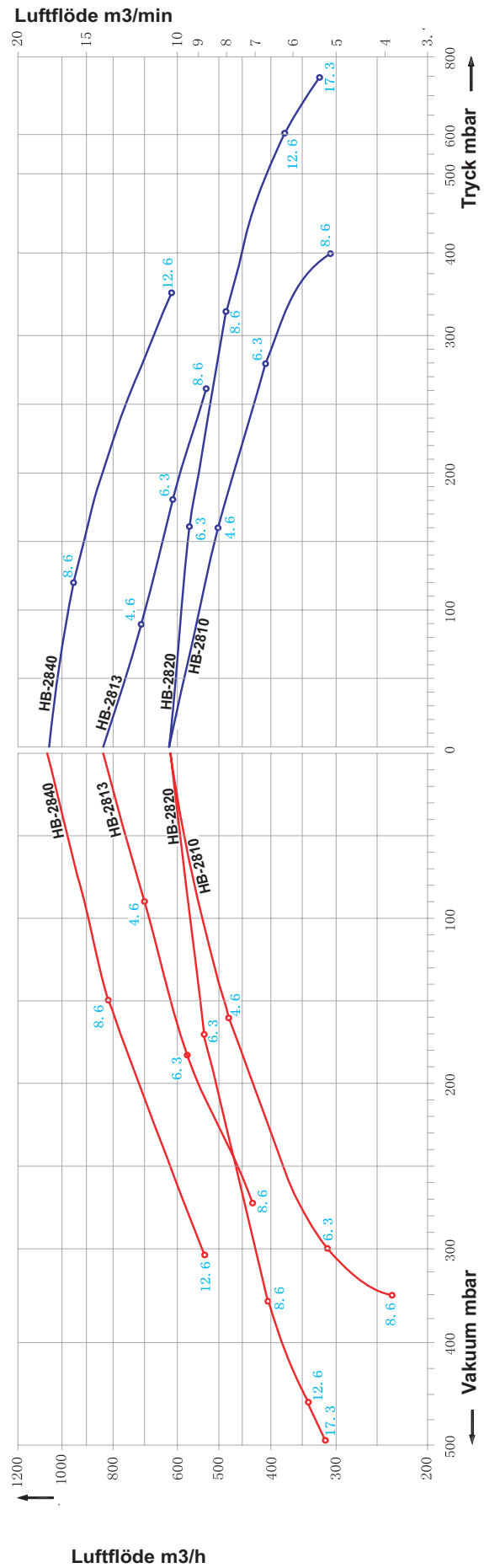



TYP	Frekvens Hz	Motoreffekt kW	Spänning V	Märkström A	Flöde max m ³ /h	Max vakuüm mbar	Max tryck mbar	Ljud dB	Vikt KG
HB 2910-850T	50	8,5	345-415/ 600-720Y	18,2/10,5Y	1050	-210	210	74	93
	60	9,8	345-415/ 600-720Y	18,2/10,5Y	1250	-180	180	79	
HB 2910-1250T	50	12,5	345-415/ 600-720Y	28/16,2Y	1050	-280	270	74	116
	60	14,5	345-415/ 600-720Y	29/16,7Y	1250	-270	260	79	
HB 2910-1850T	50	18,5	345-415/ 600-720Y	37/21Y	1050	-340	460	74	126
	60	21,3	345-415/ 600-720Y	39/22,5Y	1250	-380	420	79	
HB 2913-850T	50	8,5	345-415/ 600-720Y	18,2/10,5Y	1370	-120	110	75	98
	60	9,8	345-415/ 600-720Y	18,2/10,5Y	1650	-80	70	80	
HB 2913-1250T	50	12,5	345-415/ 600-720Y	28/16,2Y	1370	-210	190	75	121
	60	14,5	345-415/ 600-720Y	29/16,7Y	1650	-170	160	80	
HB 2913-1850T	50	18,5	345-415/ 600-720Y	38/21Y	1370	-310	320	75	131
	60	21,3	345-415/ 600-720Y	39/21,3Y	1650	-300	280	80	
HB 2920-1250T	50	12,5	345-415/ 600-720Y	28/16,2Y	1110	-300	270	74	
	60	14,5	345-415/ 600-720Y	29/16,7Y	1310	-220	200	84	
HB 2920-1650T	50	16,5	345-415/ 600-720Y	35/20Y	1110	-420	370	74	
	60	19	345-415/ 600-720Y	36,5/21Y	1310	-340	300	84	
HB 2920-2000T	50	20	345-415/ 600-720Y	40/23Y	1110	-440	500	74	
	60	23	345-415/ 600-720Y	42/24,2Y	1310	-440	430	84	
HB 2920-2500T	50	25	345-415/ 600-720Y	52/30Y	1110	-450	590	74	
	60	29	345-415/ 600-720Y	52/30Y	1310	-450	540	84	
HB 2940-1500T	50	15	345-415/ 600-720Y	35/20Y	1949	-130	110	75	
	60	17,5	345-415/ 600-720Y	36,5/21Y	2310	-60	40	84	
HB 2940-2000T	50	20	345-415/ 600-720Y	40/23Y	1940	-220	200	75	
	60	23	345-415/ 600-720Y	42/24,2Y	2310	-160	130	84	
HB 2940-2500T	50	25	345-415/ 600-720Y	52/30Y	1949	-310	270	75	
	60	29	345-415/ 600-720Y	52/30Y	2310	-270	220	84	
HB 2943-1500T	50	15	345-415/ 600-720Y	35/20Y	2050	-160	170	75	
	60	17,5	345-415/ 600-720Y	36,5/21Y	2480	-110	120	84	
HB 2943-2000T	50	20	345-415/ 600-720Y	40/23Y	2050	-250	230	75	
	60	23	345-415/ 600-720Y	42/24,2Y	2480	-190	180	84	
HB 2943-2500T*	50	25	345-415/ 600-720Y	52/30Y	2050	-310	270	75	
	60	29	345-415/ 600-720Y	52/30Y	2480	-270	230	84	

Mått HB 2910 -2913

Typ	A	B	B1	C	C'	D	E	F	F'	G	H	J	K	M	N	O	ØP	Q	ØR	S	V	YxZ	ØX	W
HB 2910-850T	550	569	55	207	15	260	415	525	230	268	300	167	533	39	89	92	100	150	15	21	4*M32x1,5	M12*30	490	42
HB 2910-1250T	550	569	55	207	15	260	415	611	230	345	300	197	533	39	89	92	100	150	15	21	4*M40x1,5	M12*30	490	54
HB 2910-1850T	550	569	55	207	15	260	415	611	230	345	300	197	533	39	89	92	100	150	15	21	4*M40x1,5	M12*30	490	54
HB 2913-850T	550	569	55	207	15	260	415	563	682	268	300	167	533	39	127	92	100	150	15	21	4*M32x1,5	M12*30	490	42
HB 2913-1250T	550	569	55	207	15	260	415	649	682	345	300	197	533	39	127	92	100	150	15	21	4*M40x1,5	M12*30	490	54
HB 2913-1850T	550	569	55	207	15	260	415	649	682	345	300	197	533	39	127	92	100	150	15	21	4*M40x1,5	M12*30	490	54

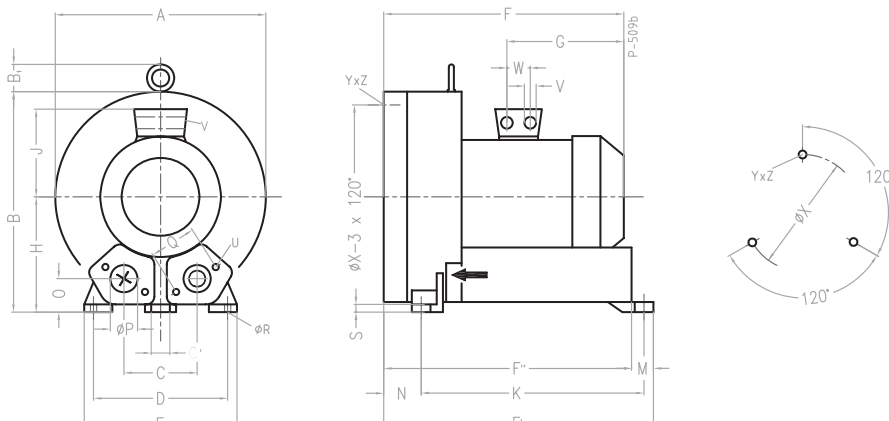

Mått HB 2920

Typ	A	B	B1	C	D	E	F	F'	G	H	J	K	M	N	O	ØP	Q	ØR	S	YxZ	W	V	ØX
HB 2920-1250T	615	607	16	103	360	415	752	786	345	300	197	533	39	230	92	100	150	15	21	M12*30	54	4xM40x1,5	490
HB 2920-1650T	615	607	16	103	360	415	752	786	345	300	197	533	39	230	92	100	150	15	21	M12*30	54	4xM40x1,5	490
HB 2920-2000T	615	607	16	103	360	415	752	786	345	300	197	533	39	230	92	100	150	15	21	M12*30	54	4xM40x1,5	490
HB 2920-2500T	615	607	16	103	360	415	752	786	345	300	197	533	39	230	92	100	150	15	21	M12*30	54	4xM40x1,5	490

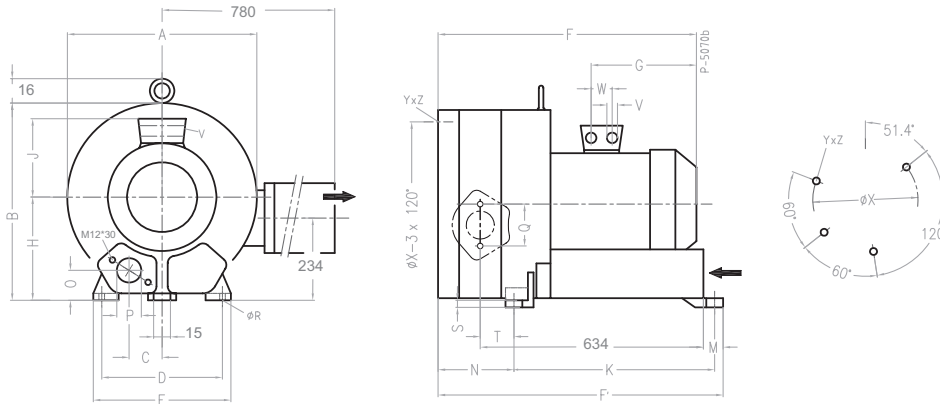

Mått HB 2940

Typ	A	B	C	C'	D	E	F	F'	G	H	J	K	M	N	O	ØP	Q	ØR	S	YxZ	W	V	ØX
HB 2940-1500T	615	657	207	15	360	415	752	786	345	350	197	533	39	280	142	100	140	15	71	M12*30	54	4xM40x1,5	490
HB 2940-2000T	615	657	207	15	360	415	752	786	345	350	197	533	39	280	142	100	140	15	71	M12*30	54	4xM40x1,5	490
HB 2940-2500T	615	657	207	15	360	415	812	786	345	350	197	533	39	280	142	100	140	15	71	M12*30	54	4xM40x1,5	490

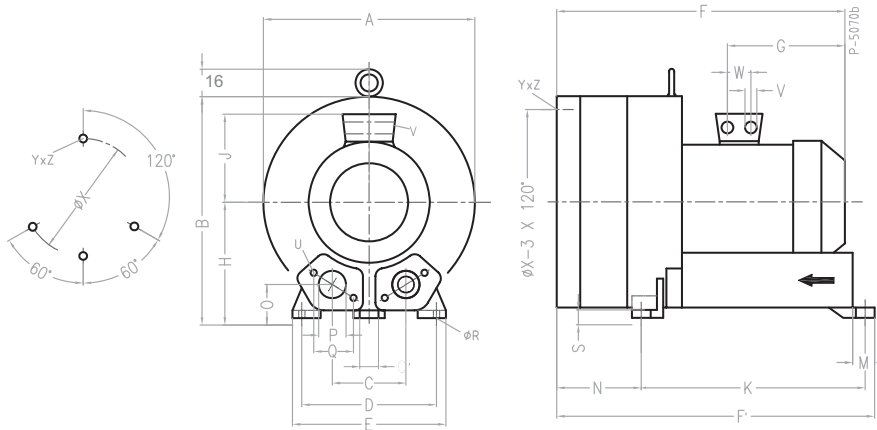

Mått HB 2943

Typ	A	B	C	D	E	F	F'	F''	G	P	P'	Q	S	W	YxZ	U	V
HB 2943-1500T	615	723	307	490	526	1201	848	578	291	219	135	201	58	54	M12*10,5	M8*40	4*M40*1,5
HB 2943-2000T	615	723	307	490	526	1201	848	578	291	219	135	201	58	54	M12*10,5	M8*40	4*M40*1,5
HB 2943-2500T	615	723	307	490	526	1201	908	578	351	219	135	201	58	54	M12*10,5	M8*40	4*M40*1,5

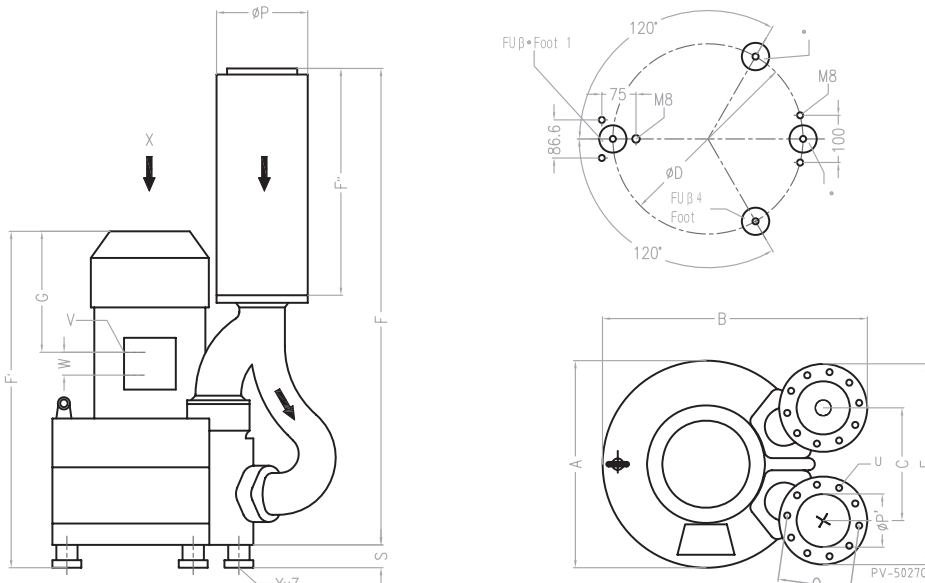

Flödesdiagram 50Hz

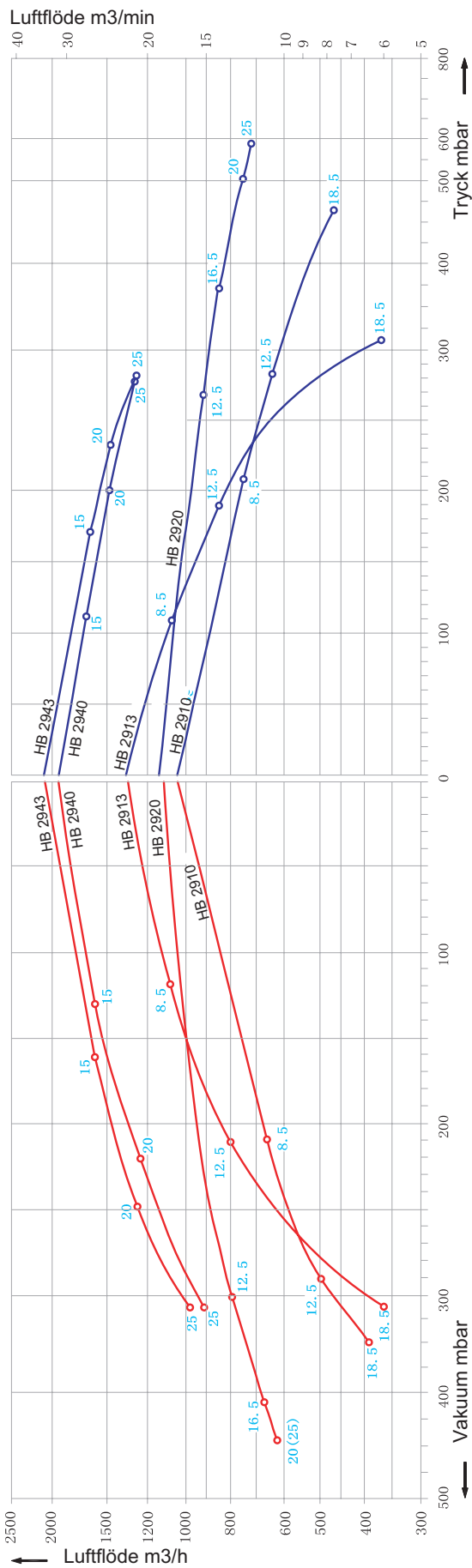

Flödesdiagram 60Hz

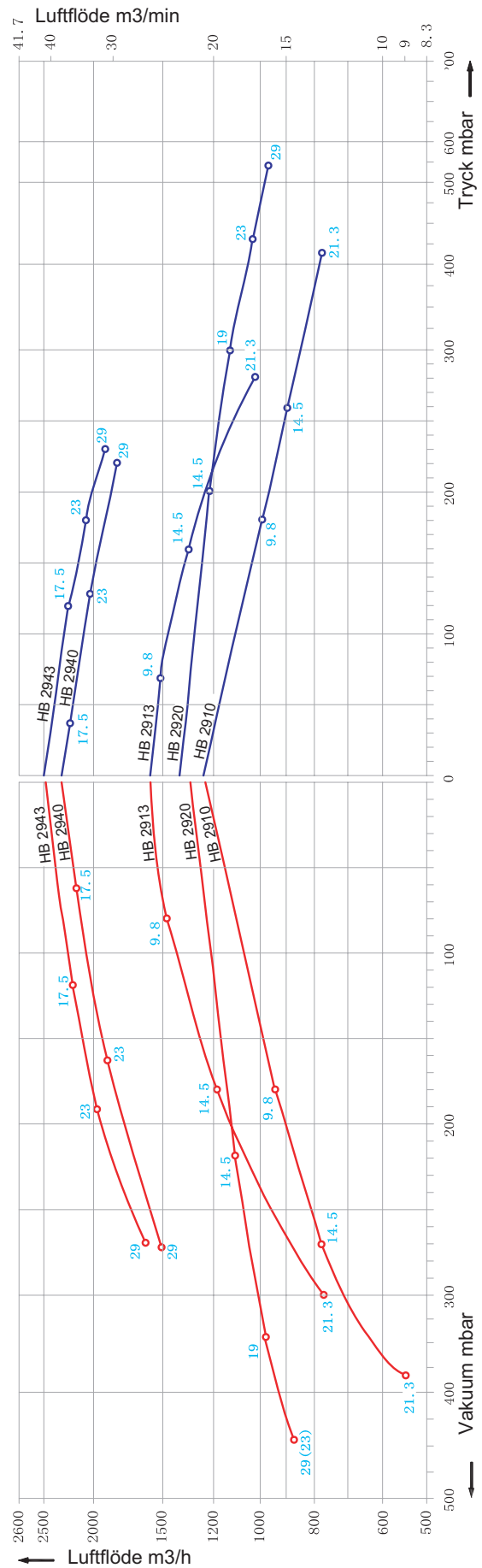

Insugsfilter ("meshfilter") MF

Typ	PT Ø	D (mm)	L (mm)	H (mm)	B (mm)	Filtration mesh	Max.flöde (l/min)	Vikt (kg)
MF-08	1"	58	170	155	42	100	110	0,2
MF-10	1¼"	71	186	170	54	100	210	0,35
MF-12	1½"	85	196	182	65	100	285	0,49
MF-16	2"	103	215	202	75	100	395	0,65
MF-20	2½"	148	274	252	97	100	750	1,2
MF-32	4"	208	380	357	142	100	1000	2,45

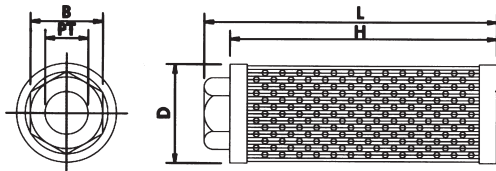

Insugsfilter IS F

Typ	A	B	C	R	Utbytesfilter
IS F-1020/10	130	90	60	1"	K.2032
IS F-1020/20	130	90	60	1¼"	K.2032
IS F-1030/10	130	115	80	1½"	K.2053
IS F-1040/10	160	135	80	2"	K.2051
IS F-1050/10	180	135	80	2½"	K.2061
IS F-1060/10	280	135	80	3"	K.2063
IS F-1065/10	320	210	115	4"	K.2068

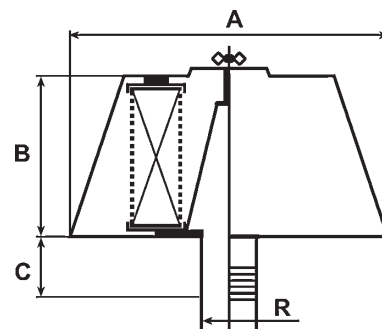

In-Line filter IL F

Typ	A	B	C	D	E	R	Utbytesfilter
IL F-004/1	133	85	17	43	78	1"	K.2032
IL F-004	133	85	17	53	78	1¼"	K.2032
IL F-005	170	170	18	124	100	1½"	K.2070
IL F-006	200	240	18	124	114	2"	K.2050
IL F-006/1	200	240	18	124	114	2½"	K.2050
IL F-008	270	180	50	145	165	4"	K.2063
IL F-010	360	590	50	400	230	4"	K.2086

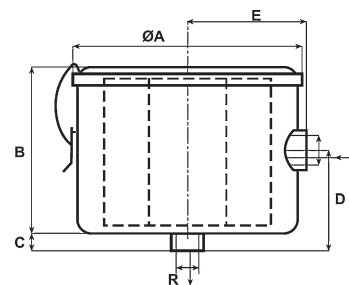

Ventil för Tryck/Vakuumbegränsning (Relief valve), RV

Typ RV-03 & RV-36 är enklare i sitt utförande och är tillverkade i plast.
Typ RV-A är mycket robusta och tillverkade i CNC fräst stål och aluminium.

Typ	D Ø	L	C	d1Ø	d2Ø	Tryckområde
RV-03	G1¼"	143	21,5	58	53	0-300 mbar
RV-36	G1¼"	143	21,5	58	53	300-600 mbar
RV-A03	G1¼"	180	22	62	62	0-300 mbar
RV-A36	G1¼"	180	22	62	62	300-600 mbar
RV-A25	G2½"	180	22	88	88	280-350 mbar

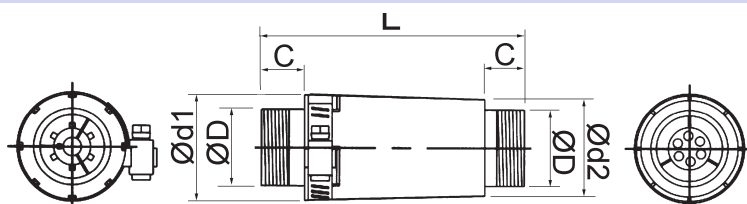

Ljuddämpare, SIL

Tillverkade i galvaniserat stål med perforerat innerrör och ljudisolation i polyuretanut för bästa ljudabsorbktion.

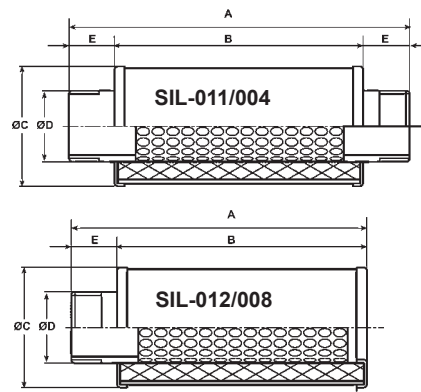

Typ	A	B	C	D	E	Vikt
SIL-011	240	140	70	1"	50	0,5
SIL-001	240	140	70	1 1/4"	50	0,5
SIL-002	230	170	80	1 1/2"	30	0,6
SIL-003	260	200	90	2"	30	0,7
SIL-004	570	400	152	3"	85	2,5
SIL-012	190	140	70	1"	50	0,5
SIL-005	190	140	70	1 1/4"	50	0,5
SIL-006	200	170	80	1 1/2"	30	0,6
SIL-007	230	200	90	2"	30	0,7
SIL-008	485	400	152	3"	85	2,5

T-rör med gängade anslutningar, T-galv

Typ	ØA	ØB
T-galv 25/25	R 1"	R 1"
T-galv 32/32	R 1 1/4"	R 1 1/4"
T-galv 40/40	R 1 1/2"	R 1 1/2"
T-galv 40/32	R 1 1/2"	R 1 1/4"
T-galv 50/50	R 2"	R 2"
T-galv 50/32	R 2"	R 1 1/4"
T-galv 65/50	R 2 1/2"	R 2"
T-galv 80/50	R 3"	R 2"
T-galv 100/50	R 4"	R 2"
T-galv 100/100	R 4"	R 4"

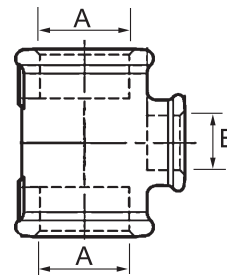

Böj 90° med gängade anslutningar, B90-galv

Typ	ØA
B90-galv 100	R 4"
B90-galv 80	R 3"
B90-galv 65	R 2 1/2"
B90-galv 50	R 2"
B90-galv 40	R 1 1/2"
B90-galv 32	R 1 1/4"
B90-galv 25	R 1"

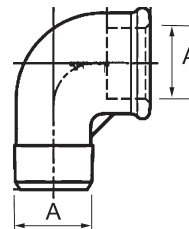

Nippelrör med gängade ändar, NP

Typ	Ø
NP 100	R 4"
NP 80	R 3"
NP 65	R 2 1/2"
NP 50	R 2"
NP 40	R 1 1/2"
NP 32	R 1 1/4"
NP 25	R 1"



Gängad slangstos TB

Typ (ØxL)	ØA	Gänga
TB 50-32/70	50	1 1/4"
TB 50x70	50	1 1/2"
TB 50x100	50	1 1/2"
TB 60x70	60	2"



Gängad bussning, BG

Typ	ØDy	ØDi
BG 50-32	R 2"	R 1 1/4"
BG 40-32	R 1 1/2"	R 1 1/4"

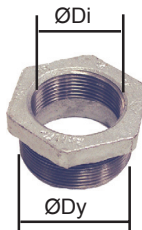

Gängad fläns, GF

Typ	Fläktstl.	ØD
GF 40	HB 24..	R 1 1/2"
GF 50	HB 25-27..	R 2"
GF 65	HB 28..	R 2 1/2"
GF 100	HB 29..	4"



Slangstos med fläns, HF

Gjutna aluminiumstosar för skruvanslutning på fläkten. Finns i Ø50 samt Ø60 för fläktstorlek HB 25.. till HB 27.. vid tidpunkt för tryckning av denna katalog.





EKB Produkter AB

Mölletofta, 264 94 KLIPPAN

Tel: **0435-226 30**, 08-26 25 30, 090-12 83 80

Fax: **0435-226 90**, 08-26 80 05

E-post: ekb@ekb.se

www.ekb.se